

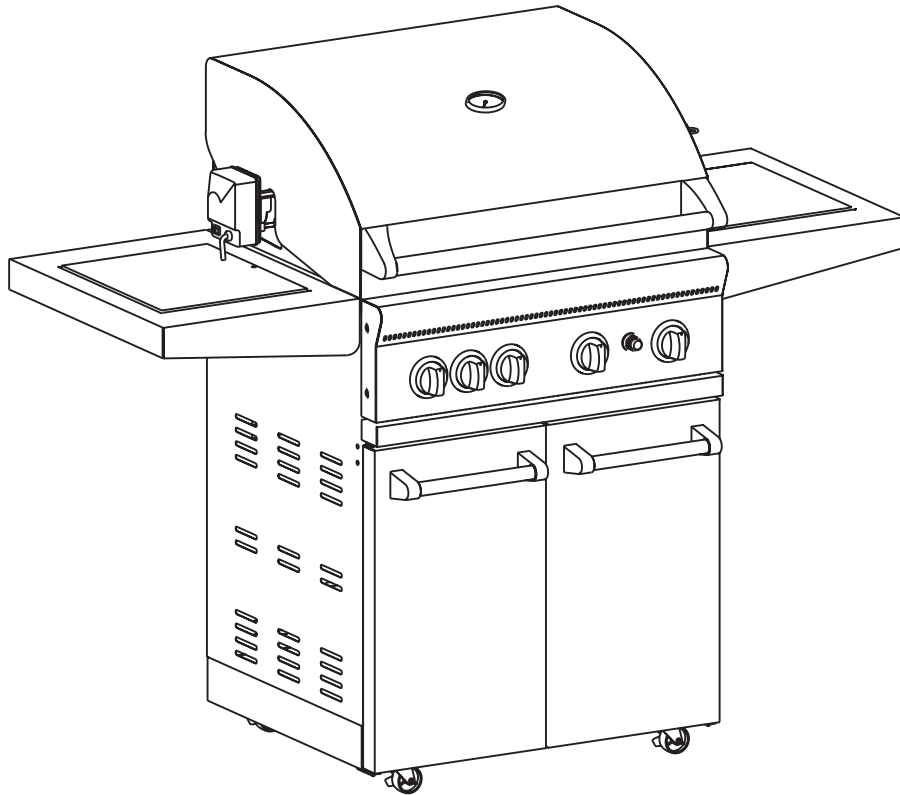

SBG2500-1, SBG2501-1 and SBG2801-1 Gas Grill Owner's Manual



IMPORTANT

This manual should be read thoroughly by the person installing the grill and all persons who will use and maintain the grill. The installer should be sure the manual is left in the possession of the user. The user should retain this manual for future reference when using or cleaning the grill and to properly identify any repair parts that may be required.

WARNING

Reference this manual for proper installation and maintenance instructions. Improper installation, adjustment, alteration, service or maintenance can cause personal injury or property damage. For assistance or additional information consult a qualified installer, service agency or the gas supplier.

**CAUTION: FOR YOUR SAFETY
IF YOU SMELL GAS:**

1. Shut off gas to the appliance.
2. Extinguish any open flame.
3. Open the grill lid.
4. If odor continues, immediately call your gas supplier or fire department.
5. Do not touch electrical switches.

CAUTION: FOR YOUR SAFETY

1. Do not store or use gasoline or other flammable vapors and liquids in the vicinity of this or any other appliance.
2. An LP cylinder not connected for use shall not be stored in the vicinity of this or any other appliance.

CAUTION:

Parts may have sharp edges. Wear leather work gloves and handle parts carefully during the unpacking, assembly and installation.

WARNING

Superb by Broilmaster® Gas Grills must ONLY use propane cylinders equipped with an Overfill Protection Device (OPD). Use only a reputable propane dealer when exchanging or filling cylinders. An over-filled or improperly filled propane cylinder can be dangerous.

Congratulations!

Welcome to the beauty and durability of a Superb by Broilmaster® Gas Grill.

At Broilmaster, we continually strive to enhance the performance and quality of our products for your grilling enjoyment. Every effort will be made to ensure that Broilmaster continues to be your choice as the grill of the future.

Whether you are at the lake or in the privacy of your own backyard, the Superb by Broilmaster® Gas Grill performs far beyond the ordinary and is designed to provide your family with years of outdoor cooking pleasure.

Thank You!

Broilmaster® is a registered trademark of

Empire Comfort Systems, Inc.

918 Freeburg Ave.

Belleville, Illinois 62220

Telephone 800-851-3153

TABLE OF CONTENTS

Congratulations!

You have chosen the finest grill for your outdoor cooking pleasure. Please take time to read this entire manual before assembling your Superb by Broilmaster® Gas Grill.

SECTION	PAGE
Hardware Package	5
Parts View	6
Parts List	7
Grill Assembly	8
Cart & Grill Assembly	9-10
Rotisserie Installation for SBG2501-1 and SBG2801-1	11-12
Propane Gas Grills	13-14
Gas Conversion to Natural Gas.....	15
Operation.....	16-17
Maintenance	18
Troubleshooting	19
Warranty Terms.....	20
Service Notes	21-23

Your Superb by Broilmaster® Gas Grill is identified by model number, serial number, and gas type. This information is provided on a product identification label located on the grill's right side of the cart. For your convenience, complete this section for future reference when contacting your dealer.

Model No. _____ Dealer _____

Serial No. _____ Dealer Phone No. _____

Gas Type: Propane _____ Natural _____ Date of Purchase _____

HARDWARE PACKAGE

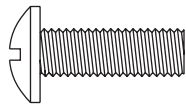

3/4" Screw (16)



Lock Washer (48)

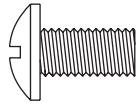

1/2" Screw (34)



"AA" Battery (1)

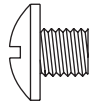

1/4" Scev (2)

PARTS VIEW

All repair part orders should be placed through your local Broilmaster® dealer. To locate a dealer in your area, contact Broilmaster Customer Service at 800-851-3153 or www.broilmaster.com. To ensure prompt and accurate service, please provide the following information when placing a repair part order: Model Number, Serial Number, Part Name, Part Number, and Quantity of parts needed.

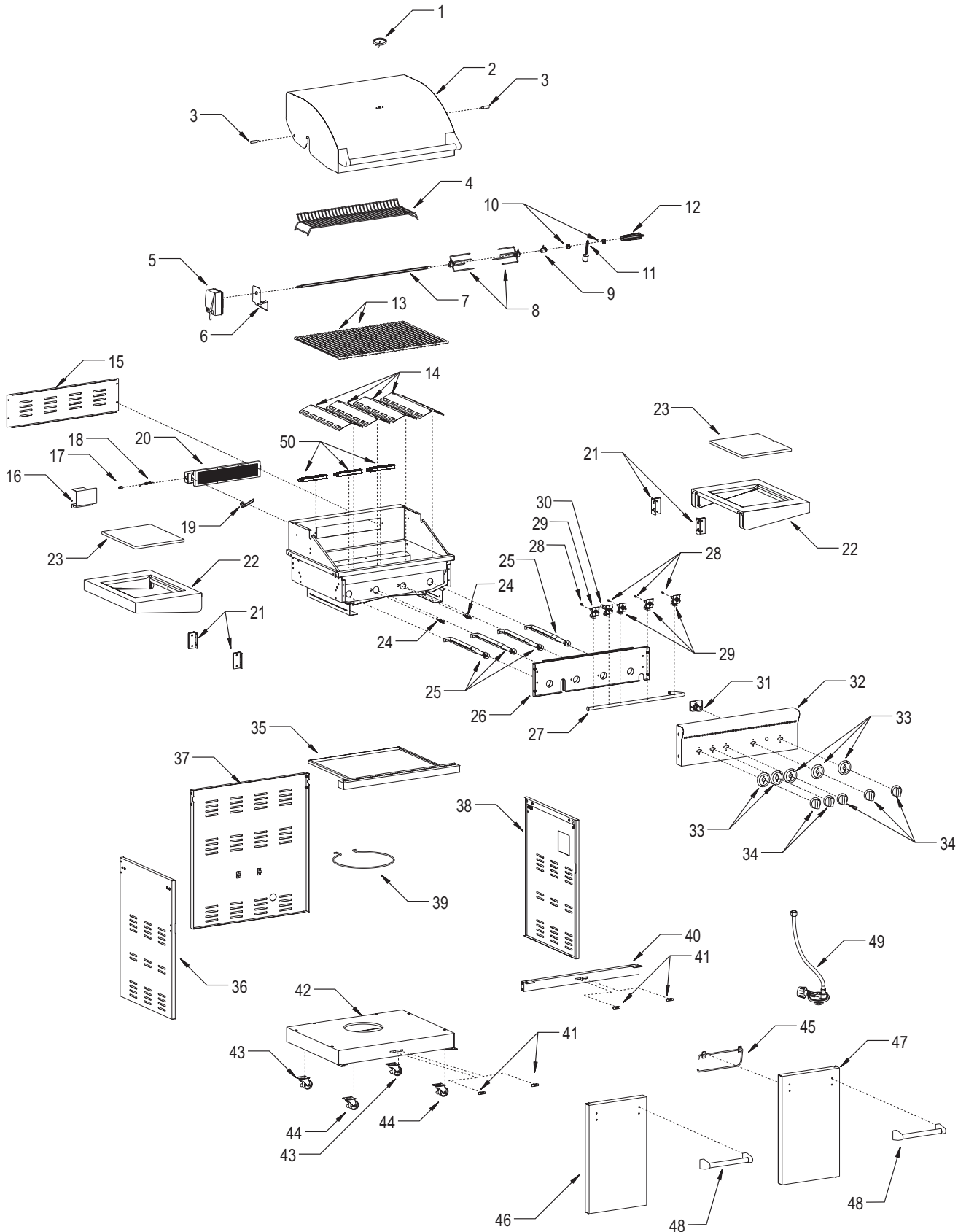

PARTS LIST

Index No.	Part Number			Description
	SBG2500	SBG2501	SBG2801	
1	SBB00014	SBB00014	SBB00014	THERMOMETER
2	SBB00011	SBB00011	SBB00012	LID
3	SBB00013	SBB00013	SBB00013	NUT AND LID
4	SBB00076	SBB00077	SBB00078	WARMING RACK
5	-	SBB00064	SBB00064	ROTISSERIE MOTOR
6	-	SBB00065	SBB00065	ROTISSERIE MOTOR BRACKET
7	-	SBB00066	SBB00067	ROTISSERIE ROD
8	-	SBB00068	SBB00068	ROTISSERIE FORKS
9	-	SBB00069	SBB00069	ROTISSERIE ROD BUSHING & SCREW
10	-	SBB00092	SBB00092	JAMB NUT
11	-	SBB00071	SBB00071	ROTISSERIE COUNTERBALANCE
12	-	SBB00070	SBB00070	ROTISSERIE ROD HANDLE
13	SBB00054	SBB00055	SBB00056	COOKING GRATE
14	SBB00052	SBB00102	SBB00102	FLAME TAMER
15	-	SBB00057	SBB00058	ROTISSERIE BURNER BACK COVER
16	-	SBB00063	SBB00063	ROTISSERIE THERMOCOUPLE SHIELD
17	-	SBB00072	SBB00073	ROTISSERIE ORIFICE LP
17	-	SBB00074	SBB00075	ROTISSERIE ORIFICE NAT
18	-	SBB00059	SBB00059	ROTISSERIE THERMOCOUPLE
19	-	SBB00060	SBB00060	ROTISSERIE ELECTRODE
20	-	SBB00061	SBB00062	ROTISSERIE BURNER
21	SBB00044	SBB00045	SBB00045	SIDE SHELF BRACKET & PIN
22	SBB00042	SBB00043	SBB00043	SIDE SHELF
23	SBB00046	SBB00046	SBB00046	CUTTING BOARD
24	SBB00050	SBB00050	SBB00050	MAIN BURNER ELECTRODE
25	SBB00051	SBB00051	SBB00051	MAIN BURNER
26	SBB00089	SBB00090	SBB00091	RADIATION SHIELD
27	SBB00039	SBB00040	SBB00041	MANIFOLD
28	SBB00030	SBB00030	SBB00030	MAIN BURNER ORIFICE LP
28	SBB00031	SBB00031	SBB00031	MAIN BURNER ORIFICE NAT
29	SBB00037	SBB00037	SBB00037	MAIN BURNER VALVE
30	-	SBB00038	SBB00038	ROTISSERIE VALVE
31	SBB00047	SBB00048	SBB00049	IGNITER
32	SBB00034	SBB00035	SBB00036	CONTROL PANEL
33	SBB00033	SBB00033	SBB00033	BEZELS
34	SBB00032	SBB00032	SBB00032	KNOBS
35	SBB00015	SBB00016	SBB00103	GREASE TRAY
36	SBB00021	SBB00023	SBB00023	CART PANEL LEFT
37	SBB00025	SBB00025	SBB00026	CART BACK PANEL
38	SBB00022	SBB00024	SBB00024	CART PANEL RIGHT
39	SBB00029	SBB00029	SBB00029	TANK RING
40	SBB00027	SBB00027	SBB00028	CART CROSS BEAM
41	SBB00010	SBB00010	SBB00010	MAGNET
42	SBB00019	SBB00019	SBB00020	CART BOTTOM
43	SBB00018	SBB00018	SBB00018	CASTER
44	SBB00094	SBB00094	SBB00094	LOCKING CASTER
45	SBB00009	SBB00009	SBB00009	TOWEL HOLDER
46	SBB00001	SBB00002	SBB00003	DOOR ASSEMBLY LEFT
47	SBB00004	SBB00005	SBB00006	DOOR ASSEMBLY RIGHT
48	SBB00007	SBB00007	SBB00008	DOOR HANDLE
49	B069756	B069756	B069756	HOSE AND REGULATOR
50	SBB00106	SBB00106	SBB00106	FLAME CARRY OVER

GRILL ASSEMBLY

Before You Begin

This grill requires some assembly and installation. Follow all instructions.

If you purchased an accessory with your Superb by Broilmaster® Gas Grill, follow the instructions provided with the accessory for assembly and installation. If an instruction refers to a step that is not required for your grill model, please continue to the next step.

CAUTION: FOR YOUR SAFETY

Parts may have sharp edges. Wear leather work gloves and handle parts carefully during the unpacking, assembly and installation.

Recommended Tools

These items are recommended for the assembly of your grill:

- Phillips screwdriver
- Soapy water solution (to test for leaks)

Grill Mountings

Refer to the instructions provided with each accessory for assembly, installation, and mounting procedures.

Gas Consumption on Grill Burners

Each Main Burner	HI	12,000 BTU/Hr
	LO	6,500 BTU/Hr
Rotisserie Burner	SBG2501-1	8,000 BTU/Hr
	SBG2801-1	12,000 BTU/Hr
Optional Side Burner	HI	13,000 BTU/Hr
	LO	5,750 BTU/Hr

CART AND GRILL ASSEMBLY

1. Place cart bottom face-down on a non-abrasive surface.
2. Attach two locking casters to front of cart bottom with four (4) lock washers, and 3/4" screws per locking caster. See Figure 1.
3. Attach two (2) non-lock casters to back of cart bottom with four (4) washers, and 3/4" screws per caster. See Figure 1.

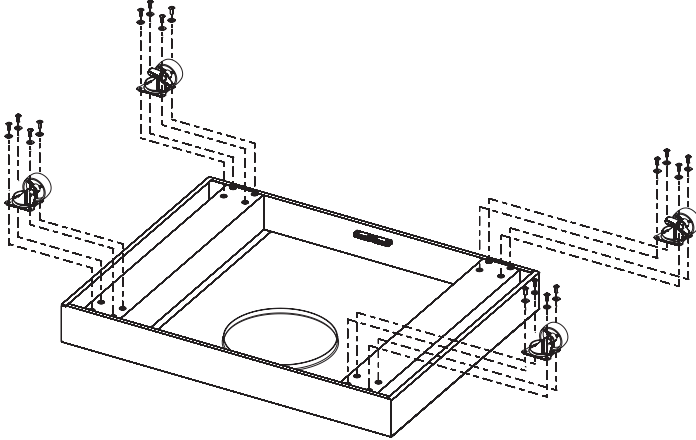

Figure 1

4. Place cart bottom face-up. Lock front casters.
5. Attach cart back to back of cart bottom with two (2) lock washers and 1/2" panel screws. See Figure 2.
6. Attach cart side panels to cart back with two (2) lock washers and 1/2" screws per cart side. Then, attach side panels to the cart bottom with two (2) lock washers and 1/2" screws per side. See Figure 2.
7. With flange on door brace positioned upward, attach door brace to cart sides with four (4) 1/2" screws. See Figure 2.

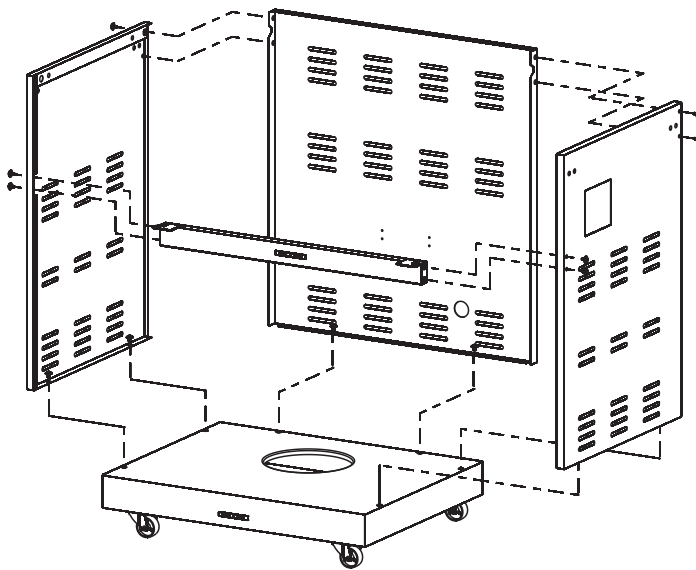

Figure 2

8. Place bottom pivot pins on doors into cart bottom and snap spring-loaded top pivot pins into door brace. See Figure 3.

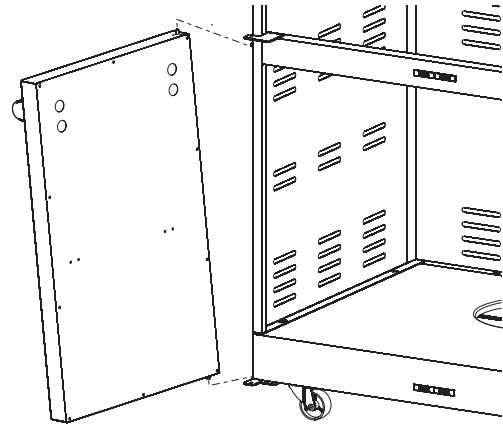

Figure 3

10. Place grill head onto cart. Attach grill head to cart from inside of the grill with four (4) lock washers, and 1/2" screws. See Figure 4.

CAUTION: Assure that gas line does not get trapped under body.

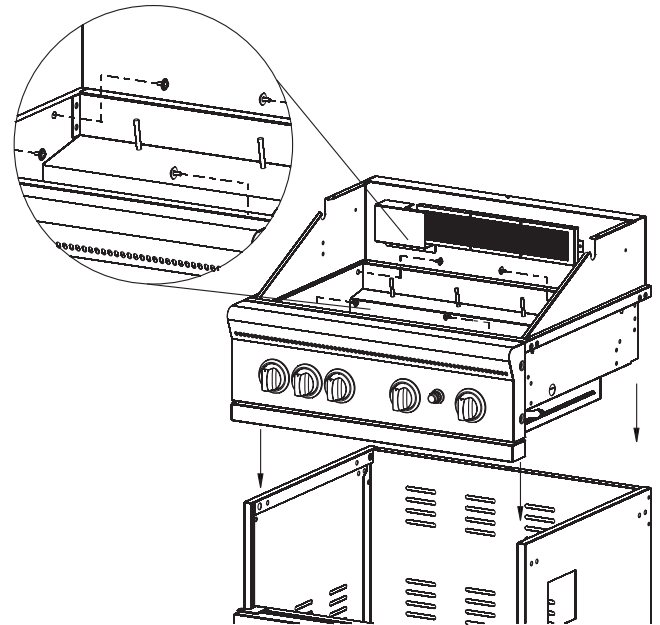

Figure 4

CART AND GRILL ASSEMBLY (cont.)

10. Pull clips off the pin which attaches the side shelf mounting bracket to the side shelf and remove pin. Remove brackets from side shelves. Attach two side shelf brackets to each cart side with four (4) lock washers and 1/2" screws per side shelf bracket. **See Figure 5.**
11. Insert and attach side shelves into side shelf brackets with one pin and clip into the top opening on each side. **See Figure 5.**

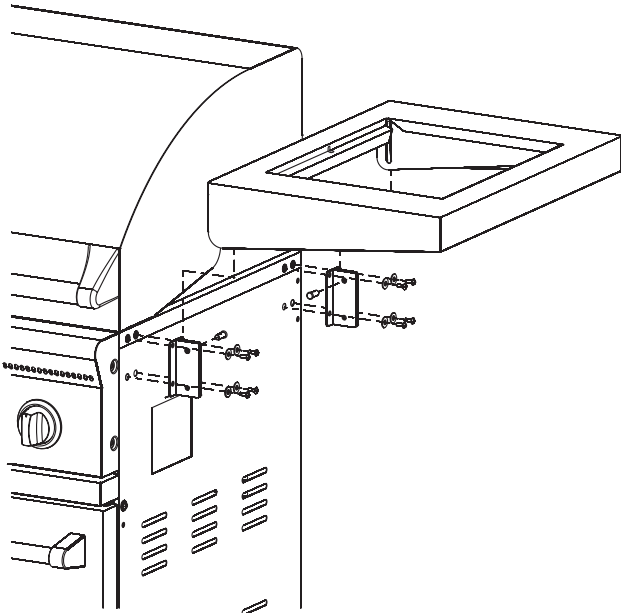

Figure 5

12. Fit screw head on cutting board to the opening on side shelf and lay the cutting board down. **See Figure 6.**

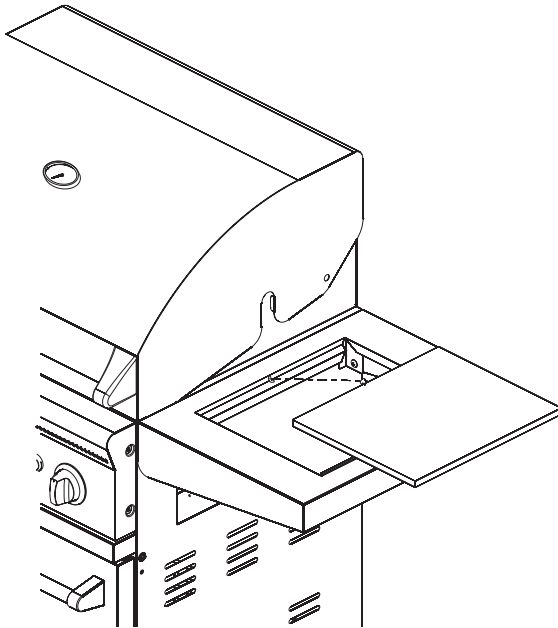

Figure 6

13. Place flame tamers over burners. Pins on burner box fit through holes on flame tamer. **See Figure 7.**
14. Place cooking grids into grill. **See Figure 7.**
15. Place warming rack on top of grill body side walls. **See Figure 7.**

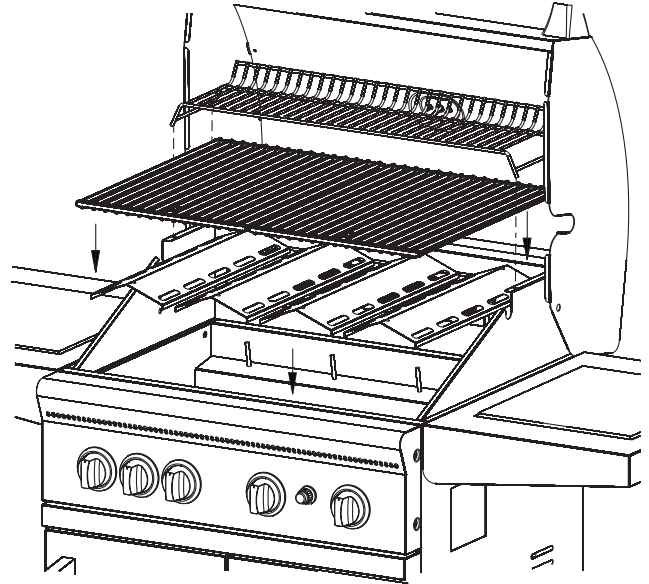

Figure 7

16. Remove ignitor button, insert AA battery positive side facing out, replace ignitor button. **See Figure 8.**

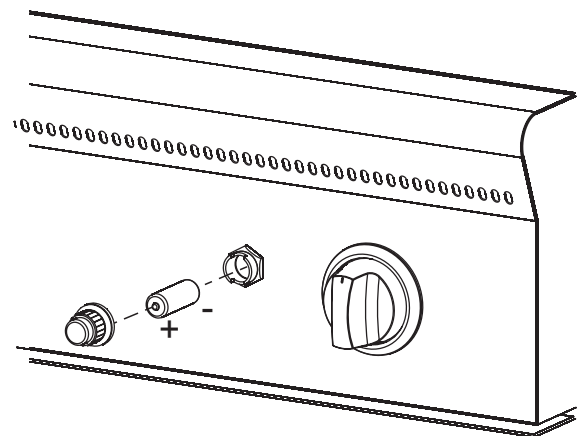

Figure 8

ROTISSERIE INSTALLATION for SBG2501-1 & SBG2801-1

The Infrared burner (Rotisserie burner) is for rotisserie cooking only. **Warning: Never use the main burners while using the Infrared Back Burner, as this could result in igniting the drippings, or overheating your grill. Remove warming rack and cooking grids.**

1. Remove all components from the carton. See Figure 9.

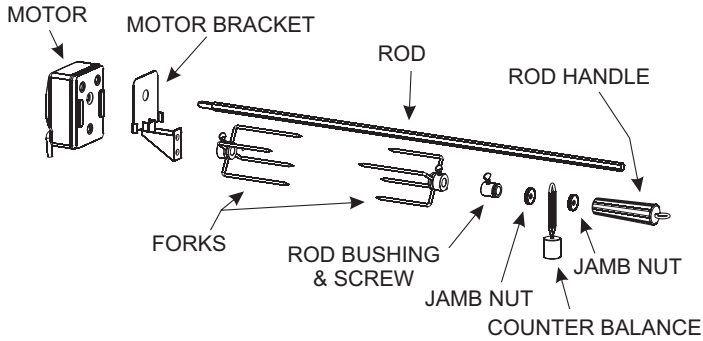

Figure 9

2. Attach the motor bracket to the left side of the grill with two (2) lock washers, and 1/4" screws. See Figure 10.

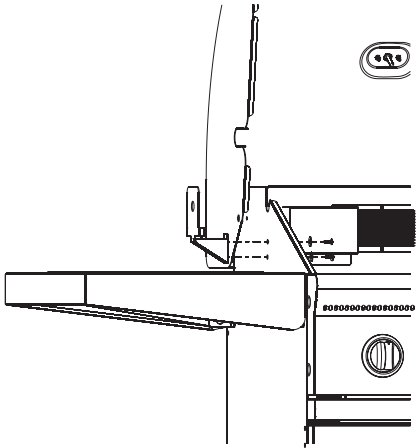

Figure 10

3. Slide motor into position on motor bracket. See Figure 11.

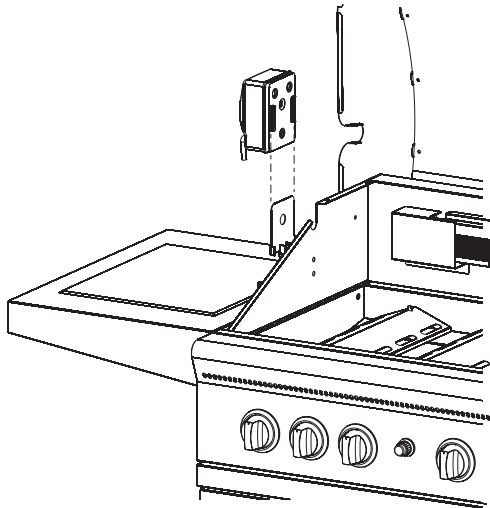

Figure 11

4. Slide a rotisserie fork onto each end of the spit. See Figure 12.
5. Adjust spacing between rotisserie forks to accommodate your food. Tighten the thumbscrews to secure the holding forks.
6. Slide the bushing onto threaded end of spit. Insert spit into slot of motor on left side of grill and place bushing into slot on right side of grill. Tighten thumbscrew on bushing. See Figure 12.

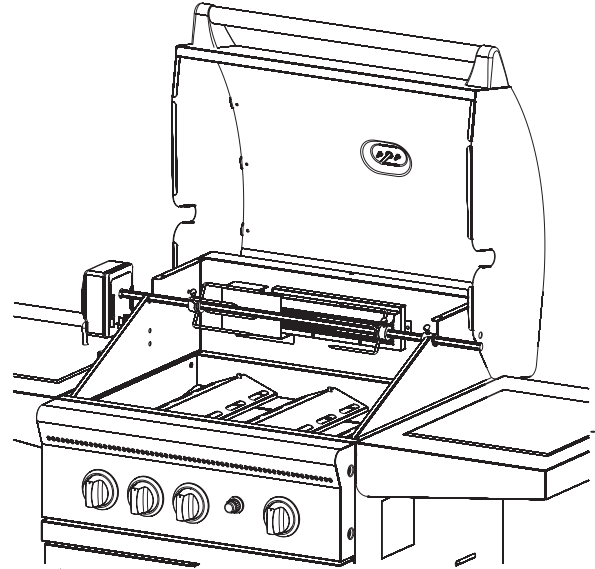

Figure 12

7. Screw jamb nut to the threaded side of spit. Slide counterbalance onto threaded end of spit. The counterbalance will remain to the outside of the grill. Screw second jamb nut into the spit to hold counterbalance in place. See Figure 13.
8. Attach handle onto spit. See Figure 13.

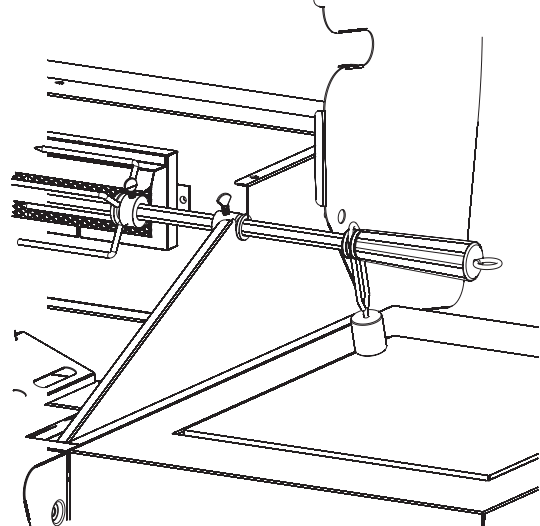



Figure 13

ROTISSERIE INSTALLATION for SBG2501-1 & SBG2801-1

Using the Ignitor

Caution: If burner fails to light after 5 seconds, turn the burner OFF for 5 minutes, to allow the gas to clear, then try again.

Attention: You must use the control knob that is second from the left side of grill to ignite the rotisserie.

1. Turn the control knob clockwise  to the OFF position.
2. Turn ON gas supply to grill.
3. With the grill lid open, push and turn the rotisserie control knob counterclockwise  to ON.
4. Push and hold the ignitor button until the rotisserie burner ignites.

Attention: When igniting the rotisserie burner, hold rotisserie control knob in for 30 seconds in order to energize the thermocouple.

5. If rotisserie burner does not ignite, turn rotisserie control knob clockwise  to the OFF position. Turn OFF gas supply to grill. Refer to Troubleshooting section in this manual.

Before rotisserie cooking you will need to remove the warming rack and the Cooking Grids from your grill. When Rotisserie Cooking you can place a Cooking pan under the food to be cooked. This will capture the drippings and keep your grill clean of excess grease which could cause a fire. Use caution when moving a cooking pan containing hot oils.

The Rotisserie Motor is rated to turn a maximum load of 12 pounds.

Warnings:

Never use the Rotisserie Motor in the rain, and never use it if it has become wet.

Always use a grounded three-prong outlet and a three-prong extension cord to energize the Rotisserie Motor.

Never alter or remove the grounding prong on the Rotisserie Power Cord, as an electric shock hazard would then result.

Never permit an electrical supply cord or gas supply line to contact any heated surface of this grill.

WARNING

The Rotisserie Motor must be electrically grounded in accordance with local codes or, in the absence of local codes, with the National Electric Code, ANSI/NFPA 70. Keep the Rotisserie Motor electric cord away from the heated surface of the grill. Do not operate the Rotisserie with a damaged cord or plug, or if the Rotisserie malfunctions or has been damaged in any manner. Call the Customer Service for replacement. The power supply cord has a 3-prong grounded plug. For your personal safety do not remove the grounding prong. It must be plugged into a mating 3-prong grounding type receptacle, grounded in accordance with the National Electrical Codes and local codes and ordinances. If an extension cord is used, it must be properly grounded and suitable for use with Outdoor Appliances. Keep the extension cord connection dry, off of the ground and out of the reach of children. When the Rotisserie Motor is not in use, remove and store in a dry area.

Rotisserie Use

Warning: Do not operate the side burner option simultaneously with the rotisserie. The side burner will melt the rotisserie handle.

Secure meat firmly to the spit rod with meat holders (It may be necessary to tie fowl and rolled roasts to retain their shape for even rotation). To ensure proper rotation, it is important to adequately balance and fasten the meat or fowl onto the spit rod.

Before heating the grill, rotate the spit rod and meat manually a few times. If out of balance, attach the counterbalance assembly to the spit to even out the weight and rotate again.

During cooking, adjust the meat holders if the meat shrinks and pulls away from the spit rod. Use gloves and caution to prevent burns.

Be certain that the rotisserie brackets and motor are secured in place, then light the burner and close the grill lid for preheating.

After preheating, place the loaded spit rod into position. Start the rotisserie motor and make certain the food is properly balanced. Close the grill lid.

Note: Beef and pork roasts and certain types of fowl will release a considerable amount of fat and juice in the process of cooking and are therefore “self-basting.” Lean meat and chicken will taste better if basted occasionally with melted butter, margarine, salad oil, barbeque sauce or a sauce of your own preference.

The exact degree of “doneness” can be determined by the use of a meat thermometer.

ROTISSERIE COUNTERBALANCE

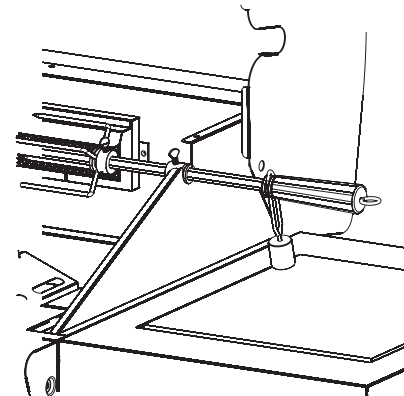

Figure 14

SCREW JAMB NUTS ONTO ROD UNTIL SNUG AGAINST COUNTERBALANCE. COUNTERBALANCE CAN BE ADJUSTED VERTICALLY FOR BEST WEIGHT DISTRIBUTION.

PROPANE GAS GRILLS

Grill Location

When choosing the ideal location for your Superb by Broilmaster® Gas Grill, remember this grill is designed for outdoor use ONLY.

You should never install or operate your grill in any building, garage, or other enclosed area.

For your safety, this grill should not be installed or operated under any combustible materials, such as carports, covered porches, awnings, or overhangs.

Never install or operate your grill in or on any recreational vehicle or boat.

CAUTION: The installation and operation of this grill at clearances less than specified below may lead to the possibility of fire, property damage, or personal injury.

A minimum clearance of 6 inches is required from the side shelves of the grill to any combustible material.

A minimum clearance of 16 inches is required from the back of the grill to any combustible material.

Some examples of combustible materials are a wall, a fence, patio furniture, or the wall of your home.

The area surrounding the grill should be clear to ensure proper ventilation. Do not obstruct the flow of combustion and ventilation air in any way. The ventilation openings on the propane cylinder enclosure must also remain free and clear of debris.

Portable grills should be level and positioned away from direct wind prior to each use.

WARNING: Do not install or operate this grill where gasoline or other flammable materials are used or stored. Failure to comply with this warning could result in explosion or fire causing property damage or personal injury.

Gas Type

Never use Liquid Propane (LP) gas with a grill designed for Natural gas, or Natural gas with a grill designed for Liquid Propane gas. The type of gas required for your grill can be determined from the product identification label located on the grill's right side panel of the cart. Questions regarding different types of gases should be directed to your gas supplier.

Cylinder Requirements

Your Superb by Broilmaster® Gas Grill requires a standard twenty (20) pound propane gas cylinder.

The maximum height allowable for a replacement cylinder is approximately twelve (12") inches (30.5 centimeters).

The propane gas cylinder must be:

1. Constructed and marked in accordance with the specifications for LP gas cylinder of the U.S. Department of Transportation (D.O.T.) or the National Standard of Canada, CAN/CSA-B339, Cylinders, Spheres, and Tubes for Transportation of Dangerous Goods; and Commission as applicable.
2. Provided with a listed overfilling protection device (OPD).

3. Provided with a listed safety device having direct access with the vapor space of the cylinder and the cylinder supply system must be arranged for vapor removal.
4. Provided with a shutoff valve terminating in a valve outlet as specified in the Standard for Compressed Gas Cylinder Outlet and Inlet Connections, ANSI CGA-V-1.
5. Provided with a plug to effectively seal off the cylinder outlet when the cylinder is being stored or transported.
6. Provided with a collar to protect the cylinder valve.

Caution: Do not use a propane gas cylinder which has a capacity greater than twenty (20) pounds with this grill and side burner.

Propane Cylinder Safety

Liquid Propane (LP) has a long history of safe use when the safety precautions provided in this manual are followed.

Failure to follow these safety precautions could result in a fire or explosion causing property damage or personal injury.

Propane gas cylinders should always be handled, stored, and transported with extreme caution in a secured upright position.

Never attempt to use or repair a propane gas cylinder that has been damaged. Never attempt to use or repair a cylinder with a faulty or damaged valve outlet. A cylinder that has been dropped, dented, or otherwise damaged must be replaced.

A propane gas cylinder should never be transported in the passenger area of a vehicle.

Keep cylinders out of direct sunlight and never apply any other source of direct heat to them.

When refilling your cylinder, always insist on a reputable, qualified gas dealer. Your propane gas cylinder is filled by weight, and should never exceed eighty (80%) percent of its weight limit. If the cylinder is not completely empty, the gas dealer must make necessary adjustments to ensure it is not overfilled. Never use an overfilled Propane gas cylinder.

Cylinder Storage

Your grill must be stored outdoors in a well ventilated area if the cylinder is attached to it.

Disconnected cylinders must have a threaded valve plug tightly installed and must not be stored in any building, garage, or other enclosed area.

Flammable materials (gasoline, grill covers, etc.) must not be stored in the cylinder enclosure.

Always store Propane cylinders in a secured upright position, out of reach of children.

Connection Requirements

Caution: Never use Liquid Propane (LP) gas in a grill designed for Natural gas, or Natural gas in a grill designed for Liquid Propane gas. Questions regarding different types of gases should be directed to your local gas supplier.

PROPANE GAS GRILLS (cont.)

Installation must conform to local codes or, in the absence of local codes, with the National Fuel Gas Code, ANSI Z223.1. In Canada, installation shall be in accordance with CAN/CGA-B149.2 Propane Installation Code, or CAN/CGA-B149.1 Natural Gas Installation Code, and local codes where applicable. Consult your local gas supplier or propane gas dealer for code regulations and recommended procedures.

Warning: Superb by Broilmaster® Gas Grills require Liquid Propane (LP) cylinders equipped with an Overfill Protection Device (OPD). An overfilled or improperly filled Propane cylinder can be dangerous.

Always use the pressure regulator and hose assembly supplied with your Propane gas grill.

Note: Not all valve and cylinder combinations are compatible. Check warning tag on valve and cylinder as well as external fitting threads.

All Broilmaster pressure regulators and hose assemblies require Propane cylinders with a Type 1 connection device as illustrated. See Figure 16.

Pressure Regulator and Hose Assembly

The pressure regulator has an outlet pressure of not more than eleven (11") inches water column. It must be connected to the Propane gas cylinder's female valve outlet before the grill can be operated.

Caution: Operation of a propane gas grill without the pressure regulator and hose assembly will cause gas leaks which could lead to fire or explosion, resulting in property damage or personal injury.

The pressure regulator's fitting must remain clean and free of nicks and scratches. A dirty, nicked or scratched fitting can cause a gas leak, resulting in an explosion or fire. Use only genuine Broilmaster® replacement parts unless otherwise specified by the manufacturer.

Connecting to Propane Gas / Cylinder Retention Means

Attention: Propane gas cylinders that are acceptable for use with this grill must comply with "Cylinder Requirements" section and "Connection Requirements" section (Pages 13-14.)

Lift up the tank ring. Position the cylinder in the opening at the bottom of the cart then fit the tank ring out side of the tank. See Figure 15.

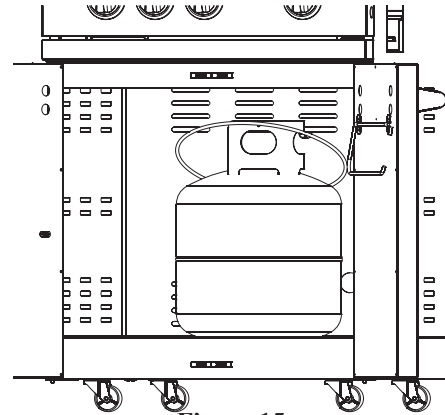
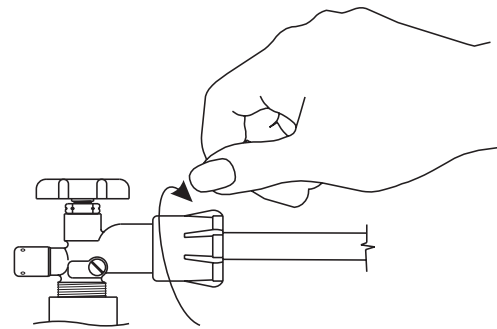

Figure 15

Attach the pressure regulator to the Propane gas cylinder's valve using the plastic handwheel. Tighten in a clockwise motion to achieve a gas tight seal. See Figure 16.



Clockwise

Figure 16

Caution: Do not use a wrench or any other tool to tighten. Use of a wrench or other tool will damage the plastic handwheel.

Fit hose to the hook inside of the right side panel. See Figure 17.

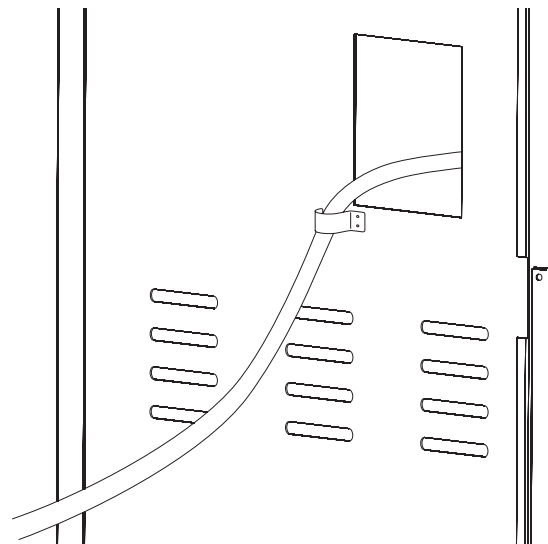

Figure 17

To disconnect the Propane gas cylinder, turn OFF the cylinder's valve and the grill's control valve. Remove the regulator by turning the plastic handwheel counterclockwise.

GAS CONVERSION TO NATURAL GAS

A conversion kit to natural gas is included with your grill.

1. Remove cooking grids and flame tamer from grill.
2. Use allen wrench supplied in conversion kit to remove control knobs.
3. Remove control panel (4 Phillips screws).

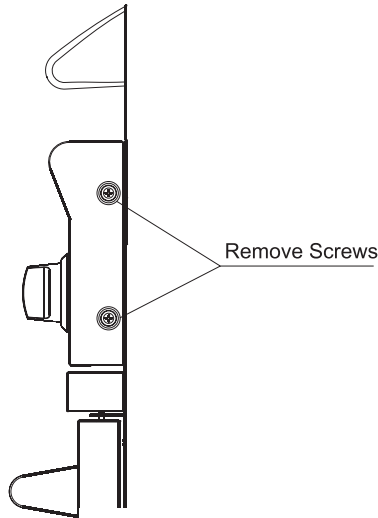

Figure 18

4. Use a 7mm socket or wrench to remove all LP gas orifices marked 1.02 from gas valves.
5. Install natural gas orifices marked 1.51 into gas valves. Apply pipe compound to threads on orifices prior to installation.
6. Attach left side of control panel to grill with two (2) Phillips screws from Step 3. Carefully insert left burner orifice into left burner. Continue to carefully insert the remaining orifices into the burners. Attach right side of control panel to grill with two (2) Phillips screws from Step 3.
7. The low input adjustment screws are located inside the main burner valve stems. Use small screwdriver supplied in conversion kit to turn each adjustment screw clockwise 1/4 turn (90 degrees).

Attention (SBG2501 and SBG2801 Only): The valve stem that is second from the left side of the grill is the rotisserie valve stem and it will not be adjusted.

8. Remove rotisserie burner back cover (5 Phillips screws - four on the back and one on inside top of the back of the grill).
9. Use a 14mm wrench or adjustable wrench to remove LP gas rotisserie orifice marked 0.84 for SBG2501 and 1.02 for SBG2801 from orifice fitting.
10. Install natural gas rotisserie orifice marked 1.18 for SBG2501 and 1.51 (orifice #53) for SBG2801 into orifice fitting. Apply pipe compound to threads on orifice prior to installation.
11. Remove the hose and regulator from the gas connection on grill with an adjustable wrench.
12. Connect the grill to the natural gas supply.
13. **Attention:** Before lighting your grill check all gas connections including the adjustment screws in valve stems for gas leaks with a soapy water mixture.

Caution: Do not use the grill if a gas leak is detected until gas leak is corrected. If a gas leak can not be stopped, do not use

grill. You must contact a qualified repair person.

14. Replace back panel (5 Phillips screws from step 8).
15. Replace all control knobs with allen wrench.
16. Apply the completed conversion label adjacent to the rating plate label on the right side panel of the cart.
17. The natural gas inlet pressure at the grill is to be set at 7.0" of inlet pressure.
18. Ignite burners on grill and observe flame pattern. If flame is yellow in color or flame is lifting off burner, the air shutter on burners will require adjustment.
19. Turn OFF (but do NOT remove) natural gas supply to grill.
20. Loosen (but do NOT remove) two (2) Phillips screws at end of each burner. Lift upward and pivot burner out of grill.
21. Loosen Phillips screw at air shutter. Air shutter for natural gas should have about 1/4" opening. Open air shutter for a yellow flame or close air shutter for a lifting flame. Tighten Phillips screw at air shutter.
22. Replace burners into grill. Tighten two (2) Phillips screws at end of each burner.
23. Ignite burners on grill to verify burner flame characteristics.

Installation must conform to local codes or, in the absence of local codes, with the National Fuel Gas Code, ANSI Z223.1. In Canada, installation shall be in accordance with CAN/CGA-B149.1 Natural Gas Installation Code, and local codes where applicable. Contact your local gas company for code regulations, recommended procedures, and the installation of your grill's gas supply line.

Caution: The grill and its individual shutoff valve must be disconnected from the gas supply piping system during any system pressure testing at test pressures in excess of 1/2 PSIG.

Caution: The grill must be isolated from the gas supply piping system by closing its individual manual shutoff valve during any pressure testing of the gas supply piping system at test pressures equal to or less than 1/2 PSIG.

OPERATION

Checking for Gas Leaks

Check for gas leaks every time you connect your Superb by Broilmaster® propane gas grill to a Propane gas cylinder, when a connected cylinder has not been used recently, or when either a natural or propane grill is being used for the first time.

Caution: Do not use a flame when checking for leaks. Checking for leaks with a flame may lead to a fire or explosion, resulting in property damage or personal injury.

To check for gas leaks:

1. Use dish washing liquid and a little water to make a soapy solution.
2. Turn OFF the knobs on the control panel.
3. Turn ON the gas at the supply or cylinder. A hissing sound indicates a leak. Turn OFF the gas and repair the leak.
4. Apply the soapy water solution to all gas connections.
5. Look for bubbles. Bubbles indicate a leak.
6. If there are bubbles turn OFF the gas and repair the leak.
7. Turn the gas back ON and repeat the above procedures until all leaks are repaired.

Air Shutter Adjustment

1. Remove cooking grids and flame tamers from grill.
2. Ignite burners on grill and observe flame pattern. If flame is yellow in color or flame is lifting off burner the air shutter on burner will require adjustment.
3. Turn gas OFF and allow the grill to cool.
4. Loosen two (2) Phillips screws at end of each burner. Lift upward and pivot burner out of grill.
5. Loosen Phillips screw at air shutter. Open air shutter for a yellow flame or close air shutter for a lifting flame. Tighten Phillips screw at air shutter.
6. Replace burners into grill. Tighten two (2) Phillips screws at end of each burner.
7. Ignite burners on grill to verify burner flame characteristics.



OPERATING INSTRUCTIONS

Using the Ignitor

Caution: If a burner fails to light after 5 seconds, turn the burner OFF for 5 minutes, to allow the gas to clear, then try again.

Attention: You should use the center burner(s) to ignite the first burner, then move from center to both sides.

Attention: The control knob that is second from left side of grill is for the rotisserie. See Rotisserie Operation on page 12.

1. Turn the right control knob clockwise  to the OFF position.
2. Turn ON gas supply to the grill.
3. With the grill lid open, push and turn the right control knob counterclockwise  to HI.
4. Push and hold in the ignitor button until the right burner ignites.
5. If right burner does not ignite, turn right control knob clockwise

 to the OFF position. Turn OFF gas supply to grill. Refer to Troubleshooting section in this manual.

OPERATING INSTRUCTIONS

Using Matches

Caution: If a burner fails to light after 5 seconds, turn the burner OFF for 5 minutes, to allow the gas to clear, then try again.

Attention: You must use the control knob on the right side of the grill to ignite the first burner. The second burner to be ignited will be the second from right side of grill and so forth, always moving from right to left.

Attention: The control knob that is second from left side of grill is for the rotisserie. See Rotisserie Operation on page 12.

1. Turn the right control knob clockwise  to the OFF position.
2. Turn ON gas supply to the grill.
3. Open the grill lid.
4. A match holder is attached on the inside of the right door. Place a match into match holder. Insert burning match through the lighter hole on right cart side. Place burning match adjacent to right burner.

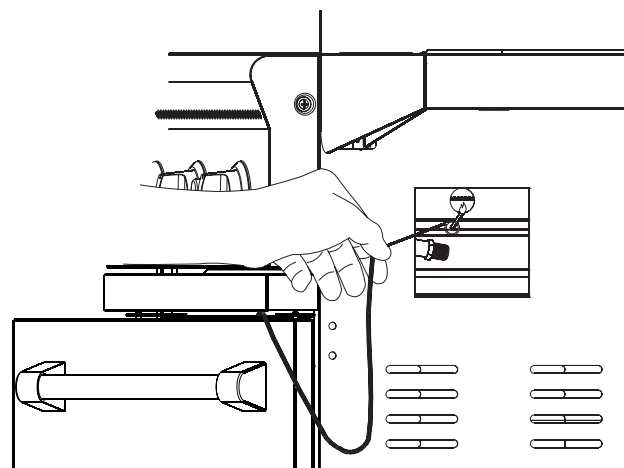



Figure 19

5. Push and turn the right control knob counterclockwise  to HI.
6. If right burner does not ignite, turn right control knob clockwise  to the OFF position. Turn OFF gas supply to grill. Refer to Troubleshooting section in this manual.

OPERATION (cont.)

Before Cooking

Before cooking on a grill for the first time, it should be “burned off” to remove any oil residue from the manufacturing process.

1. Raise the grill lid.
2. Light grill burners.
3. Burn on HI for ten minutes.
4. Close the lid and burn on HI for an additional ten minutes.
5. Turn OFF gas. The grill is now ready for use.

Preheating

Before cooking on a gas grill, allow the grill to preheat on HI for 5 minutes with the lid closed.

This uses very little fuel and provides better flavor.

Electrical Accessories

If an electrical accessory (e.g. rotisserie) is used on your grill, the accessory must be electrically grounded in accordance with local codes, or in the absence of local codes, with the National Electric Code, ANSI/NFPA 70. In Canada, the electrical accessory must be electrically grounded in accordance with the applicable section of the current Canadian Electrical Code, CSA C22.1.

Any electrical accessory should be equipped with a three-prong (grounding) plug, and plugged into a properly grounded three-prong receptacle or wall outlet. Do not cut or remove the grounding prong from the plug.

If an extension cord is required, use only a three-prong cord and plug into a properly grounded receptacle as described above.

Do not expose an electrical accessory to water. Avoid using any electrical accessory in wet weather as it may present a shock hazard.

Keep any electrical cord and fuel supply hose away from all heated surfaces.

MAINTENANCE

Cleaning the Grill

Caution: To prevent injury, do not clean a hot grill.

Note: Do not use a commercial cleaner on the cooking grids. Do not brush grids while they are hot. Do not scrape grids.

For baked on residue use a BRASS (NOT STEEL) brush on the cooking grids and other components.

Burn Off

This process is much like that used in self-cleaning ovens and is most efficient when completed after each use of the grill.

Caution: Do not open the grill during the burn off process. Opening the grill during the burn off process may cause a sudden grease fire flare up that could burn your face and arms. Wait until the grill has cooled before opening.

1. Turn control knobs to HI. Close lid and allow the grill to burn for ten minutes, or until no smoke is present. Do not allow the grill to burn for more than 30 minutes.
2. Turn control knobs and gas supply to OFF and allow the grill to cool.
3. Wipe COOL grill with a damp cloth to remove soot.

Grill Bottom

Periodically remove cooking grids and flame tamers to clean the interior of the grill. Scrape off baked on residue with a putty knife or brass brush and rinse with water. Clean the bottom air holes with a small knife.

Burner Maintenance

Stainless steel burners often turn reddish brown after use. This does not effect the performance of the grill. When cleaning the interior of the grill, remove the burners and clean with a brass brush. Wash with water and a mild detergent.

Electrode Position

Igniter electrode tips need to be placed about 1/8" from the burner surface in order to work properly. Adjust accordingly if it is misaligned. See Figure 20.

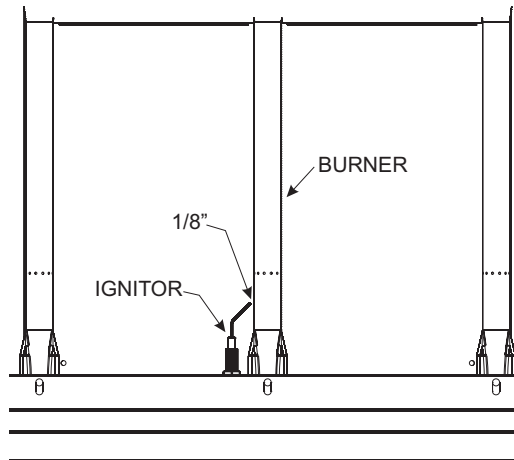

Figure 20

Grease Tray

Empty periodically.

Exterior

Clean regularly with a solution of mild detergent and hot water. Superb by Broilmaster® protective covers are recommended. Stainless steel components can be easily cleaned with a spray-on stainless steel cleaner found in most hardware stores.

Venturi Tubes

The venturi tubes allow air and gas to mix prior to burning, thus ensuring an efficient flame. Spiders or other small insects may build webs or nests inside the tubes obstructing air flow. Fire, or flashback, can occur, in and/or around obstructed venturi tubes and can cause damage to components beneath the grill or an unsafe condition. TO reduce risk, inspections and cleaning should be performed at least twice monthly when spiders are active. If the grill has been unused for an extended period of time inspect the tubes before using the grill.

Clean Rotisserie burner and venturi tubes as follows:

1. Remove rotisserie burner back cover (5 Phillips screws - 4 on the back and 1 on the inside top).
2. Use a small flexible brush to remove any debris from the venturi tubes (interior of burners).
3. Replace rotisserie burner back cover.

TROUBLESHOOTING

Although the manufacturer has attempted to ensure that your grill will operate properly and satisfactorily, sometimes problems do arise. The following troubleshooting guide lists several possible problems and their probable cause and solution.

Problem	Cause	Solution
Burner will not light.	Gas injector not inserted in venturi tube.	Realign/engage gas injector with the venturi tube.
	Clogged gas injector.	Remove gas injector from gas control assembly and clean.
	Obstruction in gas line.	For propane models, ensure gas valve on cylinder is OFF. Remove flexible hose and blow out any debris.
	Spider webs in venturi tubes.	Clean venturi tubes. See Maintenance Section..
	Misalignment of electrode.	Position electrode properly.
	Out of gas.	Refill LP gas cylinder. If natural model, turn on gas at source.
	Dead battery.	Replace with "AA" Alkaline battery.
Inadequate grill temperature.	Poor combustion.	Adjust air shutter.
	Misalignment of venturi tube and gas injector.	Realign/engage gas injector with the venturi tube.
	Inadequate gas pressure.	Contact gas supplier for assistance.
	Incorrect orifice/valve setting.	Refer to gas conversion instructions in this manual.
Flames blow out	Cold grill.	Preheat grill at least 5 minutes on HI with the grill lid closed.
	Misalignment of burner tube and gas injector.	Realign/engage gas injector with the burner tube.
	Poor combustion.	Adjust air shutter.
	Extreme wind.	Turn or shield grill.
Yellow flames.	Air shutter improperly set.	Open air shutter.
	Spider webs in venturi tubes.	Clean venturi tubes. See Maintenance Section.
	Seasoning salts on burner.	Clean by washing burner with mild detergent.
	Oil film on burner.	Allow burner to operate on HI for 10 to 15 minutes.

WARRANTY TERMS



10 Years Against Rust-Through	<ul style="list-style-type: none"> Stainless steel grill lid, grill body and cart components. Porcelain-coated steel grill body
5 Years Against Rust-Through	<ul style="list-style-type: none"> Porcelain-coated cast iron cooking grids Stainless steel burners Painted carts, mountings, and side burner housing Infrared rotisserie burners Stainless steel warming rack
2 Years Against Rust-Through	<ul style="list-style-type: none"> Stainless steel side burner assembly Porcelain-coated steel flame tamer
1 Year Against Rust-Through	<ul style="list-style-type: none"> Paint and powder coating All other parts not listed above

What Is Covered And For How Long

From the date this Superb by Broilmaster Gas Grill is first purchased, we will make available at our factory a free replacement for any defective part covered by this warranty on the following basis. Proof of purchase required. Warranty applies to original owner and is not transferable.

What Is Not Covered

- Removal and reinstallation cost.
- Labor for replacement or repairs.
- The costs of a service call to diagnose a problem.
- Transportation and shipping cost.
- Surface corrosion.
- Discoloration of stainless steel – a normal result from exposure to heat and weather – is not covered under this warranty.
- Damage caused by dropping, scraping, or abrasive cleaning voids the warranty for all cooking grids.
- Chips in the paint and porcelain coatings are not covered under warranty. Regular maintenance and cleaning - including the use of a grill cover – will help keep your grill looking great for years.
- Grills and finishes damaged by abrasive cleaning, improper installation, improper storage, accident, misuse, abuse, alteration, commercial use, and unusually harsh environmental conditions. Harsh conditions could include, but are not limited to: continual seawater spray, direct contact with pool chemicals or lawn chemicals, direct contact with corrosive materials.
- Inoperable due to improper or lack of cleaning.

This warranty does not imply or assume any responsibility for consequential damages that might result from misuse, or improper installation of this cooking appliance.

This warranty covers only claims involving defective workmanship or materials.

A bill of sale, cancelled check, or payment record should be kept to verify purchase date and establish warranty period. **Note: Empire Comfort Systems is committed to continuous product improvement. Materials and specifications are subject to change without notice.**



**THE MOST DURABLE GRILL
KNOWN TO MAN**

BROILMASTER®

A Division of Empire Comfort Systems, Inc.

918 Freeburg Ave.

Belleville, Illinois 62220

Phone: 1-800-851-3153

FAX: 1-800-443-8648

VISIT OUR WEB SITE AT www.broilmaster.com