

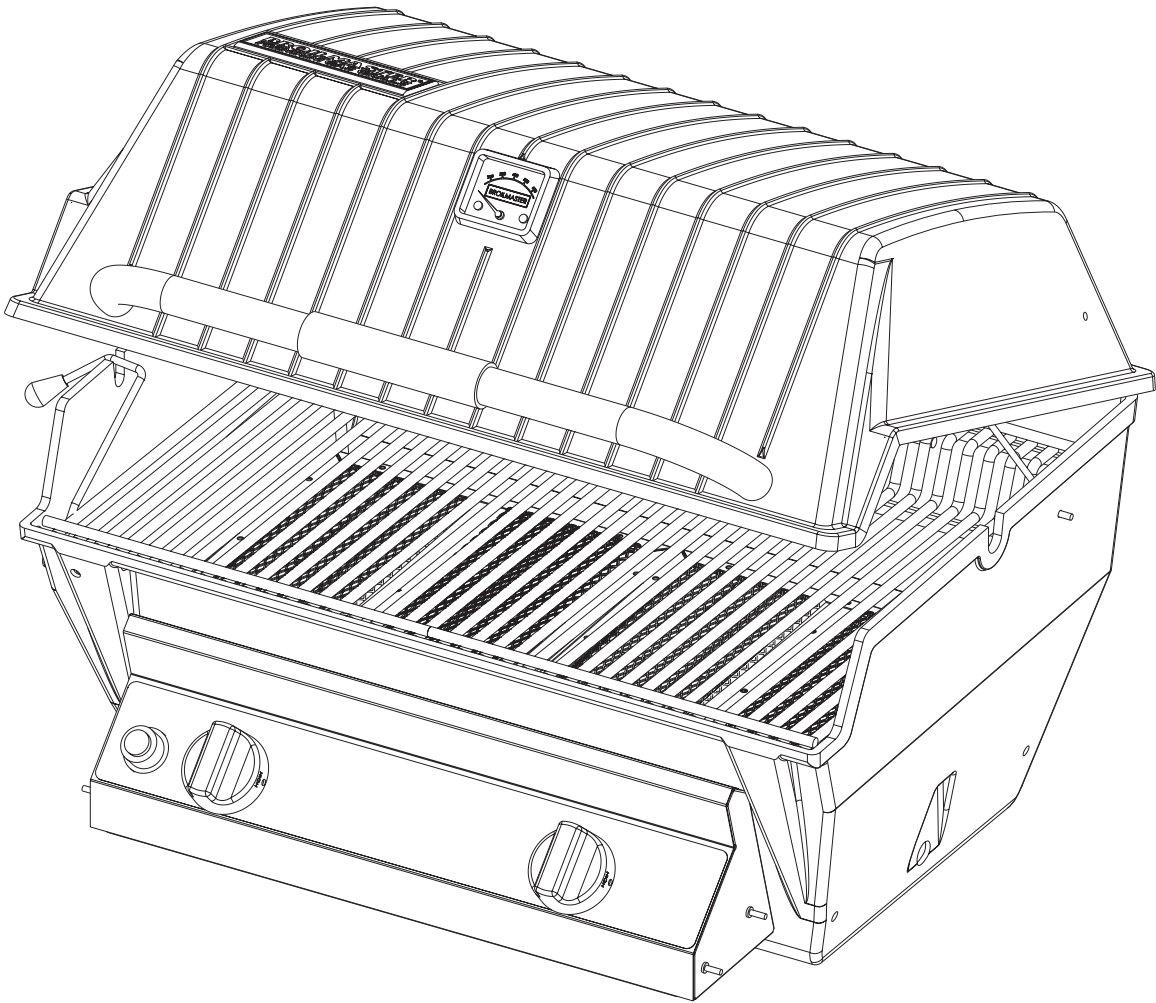

# **BROILMASTER®** **PREMIUM GAS GRILLS**

## **Premium Infrared Gas Grill Owner's Manual**



**R3-1, R3N-1 Models  
R3B-1, R3BN-1 Models**

**GAS-FIRED**



## **IMPORTANT**

This manual should be read thoroughly by the person installing the grill and all persons who will use and maintain the grill. The installer should be sure the manual is left in the possession of the user. The user should retain this manual for future reference when using or cleaning the grill and to properly identify any repair parts that may be required.

## **WARNING**

Reference this manual for proper installation and maintenance instructions. Improper installation, adjustment, alteration, service or maintenance can cause personal injury or property damage. For assistance or additional information consult a qualified installer, service agency or the gas supplier.



## **DANGER**

### **IF YOU SMELL GAS:**

1. Shut off gas to the appliance.
2. Extinguish any open flame.
3. Open the grill lid.
4. If odor continues, keep away from the appliance and immediately call your gas supplier or fire department.



## **WARNING**

1. Do not store or use gasoline or other flammable liquids or vapors in the vicinity of this or any other appliance.
2. An LP cylinder not connected for use shall not be stored in the vicinity of this or any other appliance.

## **CAUTION:**

Parts may have sharp edges. Wear leather work gloves and handle parts carefully during the unpacking, assembly and installation.

## **WARNING**

Broilmaster® Gas Grills must ONLY use propane cylinders equipped with an Overfill Protection Device (OPD). Use only a reputable propane dealer when exchanging or filling cylinders. An overfilled or improperly filled propane cylinder can be dangerous.

# Congratulations!

Welcome to the beauty, durability, and prestige of a Premium Gas Grill by Broilmaster®. With award-winning excellence built into every feature and durability that surpasses other Premium gas grills, Broilmaster has manufactured the ultimate gas grill for discriminating outdoor chefs for over 30 years.

At Broilmaster, we continually strive to enhance the performance and quality of our products for your grilling enjoyment. Every effort will be made to ensure that Broilmaster continues to be your choice as the Premium grill of the future.

Whether you are at the lake or in the privacy of your own backyard, the Broilmaster Premium Gas Grill performs far beyond the ordinary and is designed to provide your family with years of outdoor cooking pleasure.

## Thank You!

# TABLE OF CONTENTS

## Congratulations!

You have chosen the finest grill for your outdoor cooking pleasure. Please take time to read this entire manual before assembling your Premium Broilmaster gas grill.

Hardware Package .....	5
Parts Diagram .....	6
Parts List .....	7
Safety Precautions .....	8
Grill Assembly .....	9-13
Propane Gas Grills .....	14-16
Gas Conversion to Natural Gas .....	17-18
Natural Gas Grills .....	19
Infrared Cooking .....	20
Infrared Cooking Sample Times & Grid Positions .....	21-22
Operation- Propane & Natural Grills .....	23-24
Blue Flame Burner Maintenance .....	25
Infrared Burner Maintenance .....	26-27
Troubleshooting .....	28
Warranty .....	29
Notes .....	30-31

Your Broilmaster Premium Gas Grill is identified by model number, serial number, and gas type. This information is provided on a product identification label located on the grill's control panel. For your convenience, complete this section for future reference when contacting your dealer.

Model No. \_\_\_\_\_ Dealer \_\_\_\_\_

Serial No. \_\_\_\_\_ Dealer Phone No. \_\_\_\_\_

Gas Type: Propane \_\_\_\_\_ Natural \_\_\_\_\_ Date of Purchase \_\_\_\_\_

# HARDWARE PACKAGE

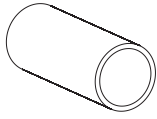

B101082 SPACER, IGNITOR

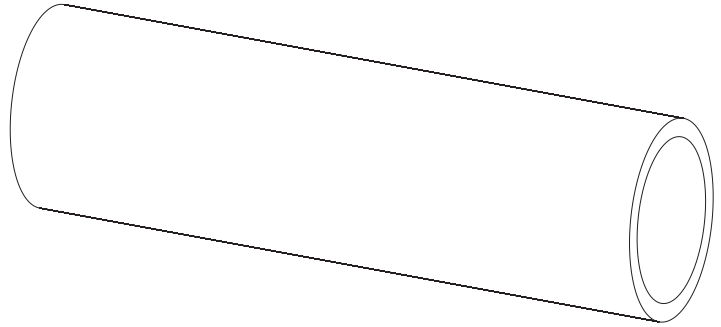

B073097 FOAM GRIP

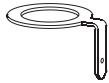

B069747 LUG, IGNITOR GROUND

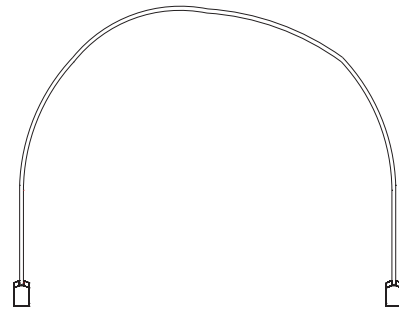

B101048 WIRE, IGNITOR GROUND

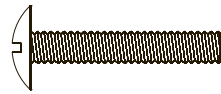

B073978 SCREW #10-24 X 1 PHILLIPS TRUSS STAINLESS

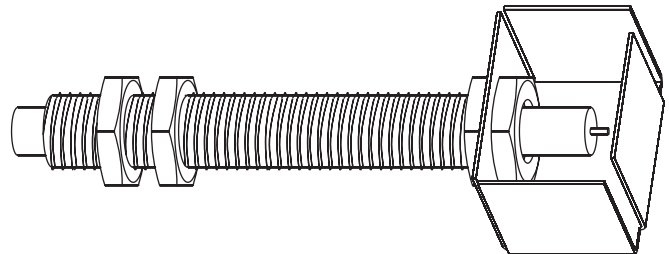

B101212 COLLECTOR BOX ASSEMBLY

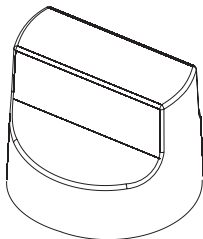

R3918 KNOB

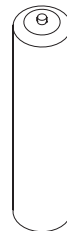

B076529 BATTERY, AA

# PARTS DIAGRAM

All repair part orders should be placed through your local Broilmaster dealer. To locate a dealer in your area, visit [www.Broilmaster.com](http://www.Broilmaster.com). To ensure prompt and accurate service, please provide the following information when placing a repair part order: Model Number, Serial Number, Part Name, Part Number, and Quantity of parts needed.

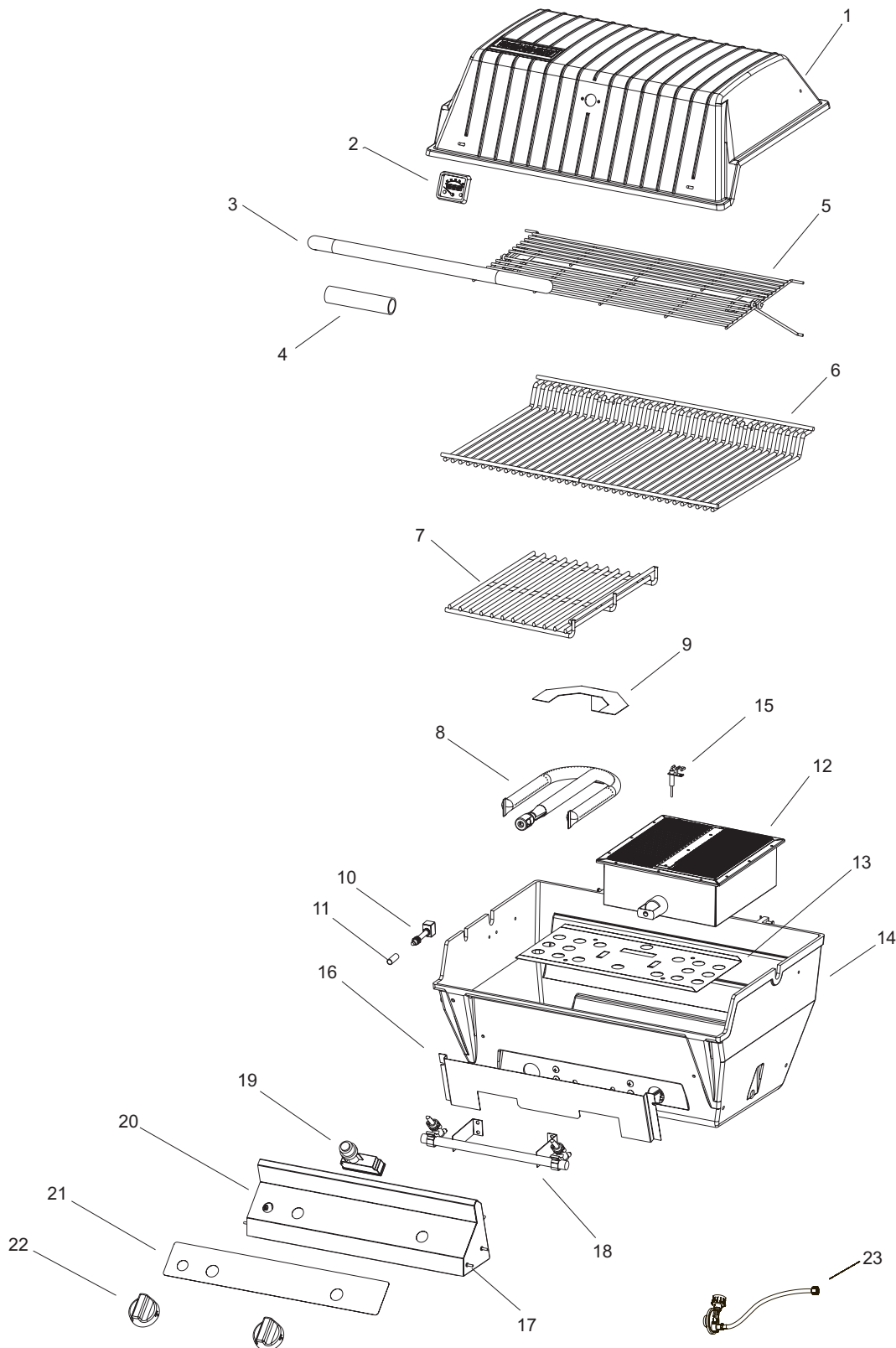

# PARTS LIST

Index Number	Description	Part Number			
		R3	R3N	R3B	R3BN
1	Grill Body Top - Black	B100456	B100456	B100456	B100456
2	Heat Indicator (Stainless)	B101118	B101118	B101118	B101118
3	Lid Handle (Stainless)	B070486	B070486	B070486	B070486
4	Foam Grip	B073097	B073097	B073097	B073097
5	Stainless Steel Retract-A-Rack	B072695	B072695	B072695	B072695
6	Stainless Steel Rod Cooking Grid	B101282	B101282	B101282	B101282
7	Briquet Rack	N/A	N/A	B101369	B101369
8	Burner	N/A	N/A	B101030	B101030
9	Burner Shield	N/A	N/A	B101154	B101154
10	Collector Box Assembly	N/A	N/A	B101212	B101212
11	Ignitor Spacer	N/A	N/A	B101082	B101082
12	Infrared Burner (1 required)	N/A	N/A	B101269	B101269
12	Infrared Burner (2 required)	B101269	B101269	N/A	N/A
13	Radiation Shield	B101045	B101045	B101045	B101045
14	Grill Body Bottom - Black	B101313	B101313	B101313	B101313
15	Infrared Ignitor (1 Required)	N/A	N/A	B101271	B101271
15	Infrared Ignitor (2 Required)	B101271	B101271	N/A	N/A
16	Valve Shield	B101046	B101046	B101046	B101046
17	Pin, Shelf	B073963	B073963	B073963	B073963
18	Manifold And Valve Assembly	B101356	B101316	B101314	B101317
19	Electronic Ignitor	B072218	B072218	B072218	B072218
20	Control Panel Assembly	B101033	B101033	B101033	B101033
21	Control Panel Label	B101272	B101272	B101272	B101272
22	Valve Knob	R3918	R3918	R3918	R3918
23	Hose And LP Regulator	B069756	N/A	B069756	N/A
N/S	Char-Master Briquets	N/A	N/A	B101323	B101323
N/S	Hardware Pack	B101274	B101275	B101309	B101310
N/S	Bridge Pin	B057805	B057805	B057805	B057805
N/S	Hinge Pin	B057804	B057804	B057804	B057804
N/S	Natural Gas Conversion Kit	B101276	N/A	B101311	N/A
N/S	Cast Stainless Steel Cooking Grids (Optional)	DPA101	DPA101	DPA101	DPA101
N/S	Ground Lug (2 Required)	B069747	B069747	N/A	N/A
N/S	Ground Wire	B072684	B072684	N/A	N/A
N/S	Hardware Pack, Adjustable Lid Stop	B101097	B101097	B101097	B101097

N/S - NOT SHOWN

# SAFETY PRECAUTIONS

## Safety Practices to Avoid Personal Injury

When properly cared for your Broilmaster Infrared Grill will give safe, reliable service for many years. However, extreme care must be used since the grill produces intense heat, which can increase accident potential. When using this appliance, basic safety practices must be followed, including the following:

**Read this Installation Instructions and Owner's Manual carefully and completely before using your grill to reduce the risk of fire, burn hazard or other injury.**

Begin by ensuring proper assembly.

Do not repair or replace any part of the grill unless specifically recommended in this manual. All other service should be referred to a qualified technician.

For personal safety, wear proper apparel. Loose fitting garments or sleeves should never be worn while using this appliance. Some synthetic fabrics are highly flammable and should not be worn while cooking. Never let clothing, pot holders or other flammable materials come in contact with or too close to any grate, burner or hot surface until it has cooled. Fabric may ignite and result in personal injury.

Use only dry pot holders: moist or damp pot holders on hot surfaces may cause burns from steam. Do not use a towel or bulky cloth in place of pot holders. Do not let pot holders touch hot portions of the grilling grids.

Only certain types of glass, heat-proof glass ceramic, earthenware, or other glazed utensils are suitable for grill use. Use of these types of materials may break with sudden temperature changes.

Grease is flammable. Let hot grease cool before attempting to handle it. Avoid letting grease deposits collect in the bottom of the grill. Clean often.

Do not use aluminum foil to line the grilling grids or grill bottom. This can severely upset combustion airflow or trap excessive heat in the control area. The result of this can be melted knobs, igniters and increased chance of personal injury. The drip tray accessory may be lined with aluminum foil.

Children should not be left alone or unattended in an area where the grill is being used. Never allow them to sit, stand or play on or around the grill at any time. Do not store items of interest to children around or below the grill or in the cart. Never allow children to crawl inside of a cart.

Do not heat unopened food containers as a build-up of pressure may cause the container to burst.

Use a covered hand when opening the grill lid. Never lean over an open grill.

When lighting a burner, always pay close attention to what you are doing. Be certain you are depressing the igniter button. When using the grill: do not touch the grilling grids, burner, warming rack or immediate surrounding area as these areas become extremely hot and could cause burns.

For proper lighting and performance of the burners keep the ports clean. The burners will only operate in one position and must be mounted correctly for safe operation.

Clean the grill with caution. Avoid steam burns; do not use a wet sponge or cloth to clean the grill while it is hot. Some cleaners produce noxious fumes or can ignite if applied to a hot surface.

**Insect Warning** - Spiders and insects can nest in the burners of this and any other grill, and cause the gas to flow from the front of the burner. This is a very dangerous condition, which can cause a fire to occur behind the valve panel, thereby damaging the grill and making it unsafe to operate. Inspect the grill at least twice per year.

Be sure all grill controls are turned off and the grill is cool before using any type of aerosol cleaner on or around the grill. The chemical that produces the spraying action could, in the presence of heat, ignite or cause metal parts to corrode. Do not operate the grill under unprotected combustible construction. Use only in well ventilated areas. Do not use in buildings, garages, sheds, breezeways or any enclosed areas.

Keep the area surrounding the grill free from combustible materials, trash, or combustible fluids and vapors such as gasoline or charcoal lighter fluid. Do not obstruct the flow of combustion and ventilation air. Keep the back of the cart free and clear from debris.

If the unit is stored indoors ensure that it is cool. If propane is used, the cylinder must be unhooked and the propane cylinder stored outside in a well-ventilated area, out of reach of children.

Never use the grill in windy conditions. If located in a consistently windy area (oceanfront, mountain top, etc) a windbreak will be required. Always adhere to the specified clearance.

Keep any electrical supply cord, or the optional rotisserie motor cord away from the heated areas of the grill. Do not use the grill for cooking excessively fatty meats or products, which promote flare-ups.

### **OUTDOOR USE ONLY**

Your Broilmaster Infrared Grill is designed for outdoor use only and must not be installed in or on recreational vehicles and/or boats.

**NEVER USE A DENTED OR RUSTY PROPANE TANK.  
SHUT OFF TANK WHEN NOT IN USE.**



# GRILL ASSEMBLY

## Before You Begin

All Broilmaster grills require some assembly and installation. Follow all instructions unless noted to apply only to other specific models.

If you purchased an accessory with your Broilmaster, follow the instructions provided with the accessory for assembly and installation. If an instruction refers to a step that is not required for your grill model, please continue to the next step.

In each step, parts are identified with “Key” numbers. Key numbers appear in parenthesis after a part name is mentioned for the first time in the instructions. You can reference each part by its key number on the Parts List if you need help in identifying a part.

Compare the parts found in the shipping container to the parts list provided. If any parts are missing contact your Broilmaster dealer before beginning assembly.

### **CAUTION: FOR YOUR SAFETY**

**Parts may have sharp edges. Wear leather work gloves and handle parts carefully during the unpacking, assembly and installation.**

### **CAUTION: Hood Position**

Due to the intense heat generated by the Broilmaster burner system, cooking with the hood closed **can only** be done with the control knobs set on LOW. The control panel label clearly indicates the highest safe setting for cooking with the hood closed.

## Recommended Tools

These items are recommended for the assembly of your grill:

- Phillips screwdriver
- Adjustable wrench set
- Socket set
- Soapy water solution (to test for leaks)
- Liquid soap (for foam grip)

## Grill Mountings

Assemble your base option before assembling your Broilmaster grill head.

Refer to the Broilmaster Cart, Base, and Post instructions provided with each accessory for assembly, installation, and mounting procedures.

# GRILL ASSEMBLY

1. Mount grill onto cart, post or base per the mounting instructions.
2. Place radiation shield (13) (flange side up) onto four raised bosses located on the interior bottom of the grill. See Figure 1.

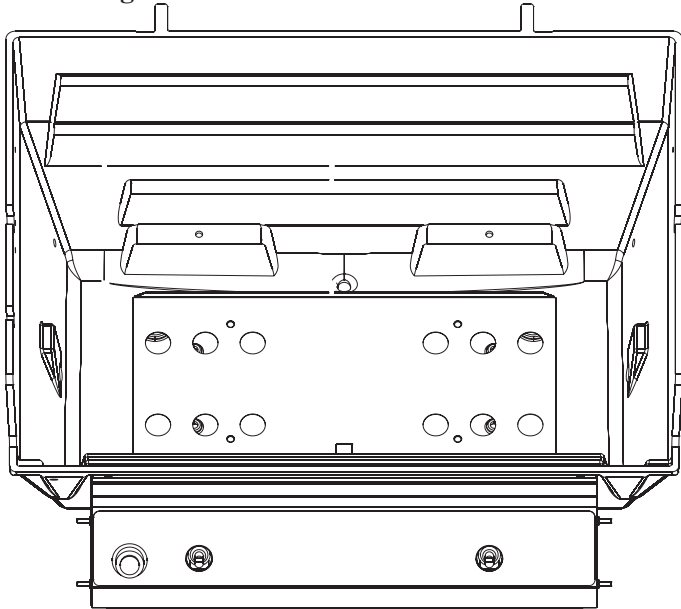

Figure 1

3. R3B model only: Slide ignitor spacer (11) onto collector box assembly (10) and secure with nuts. See Figure 2.

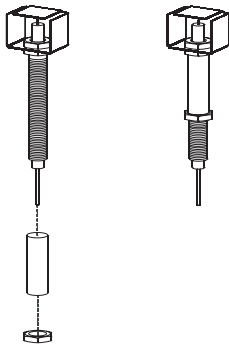
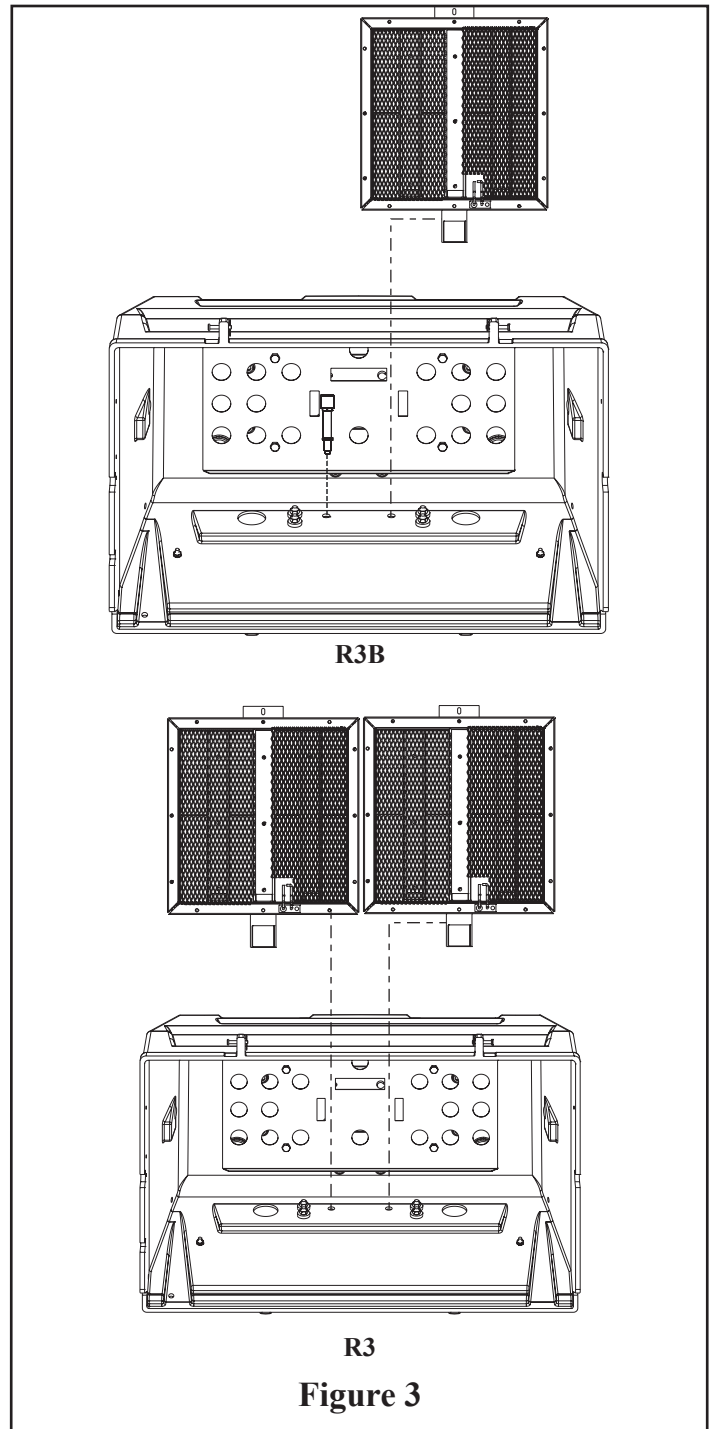

Figure 2

**Attention:** Do not cut or damage ignitor wires.

4. R3B model only: Insert collector box assembly into hole adjacent to burner. The opening of the collector box should be facing the burner. The infrared ignitor wire slides through the empty hole next to the burner. See Figure 3.



# GRILL ASSEMBLY

5. Place blue flame burner on the left and infrared on the right into grill and insert burner tubes over orifice fittings on valve (17). Secure each burner and burner shield (9) with one (1) 1/4-20 x 3/4 phillips screw and nut. See Figures 4, 5 and 6. R3 model only: Use lugs to attach ground wire before screwing the two infrared burners on. See Figure 6. Tuck ground wire underneath the burners to prevent damage.

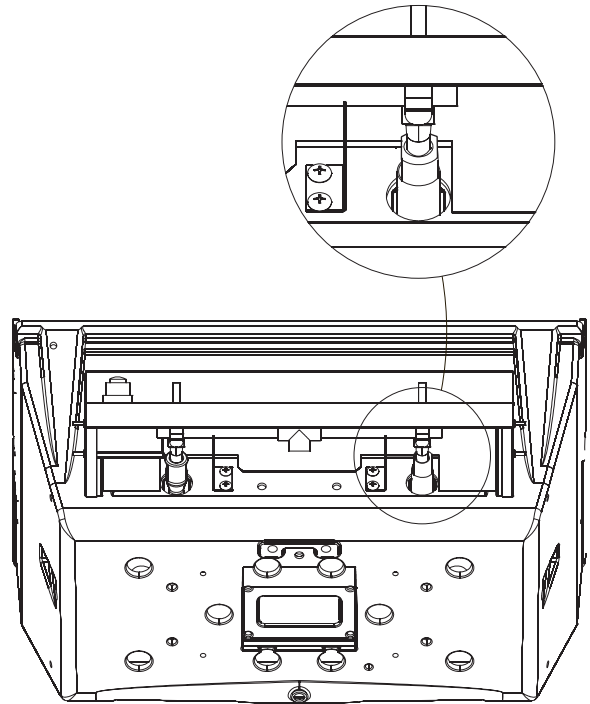
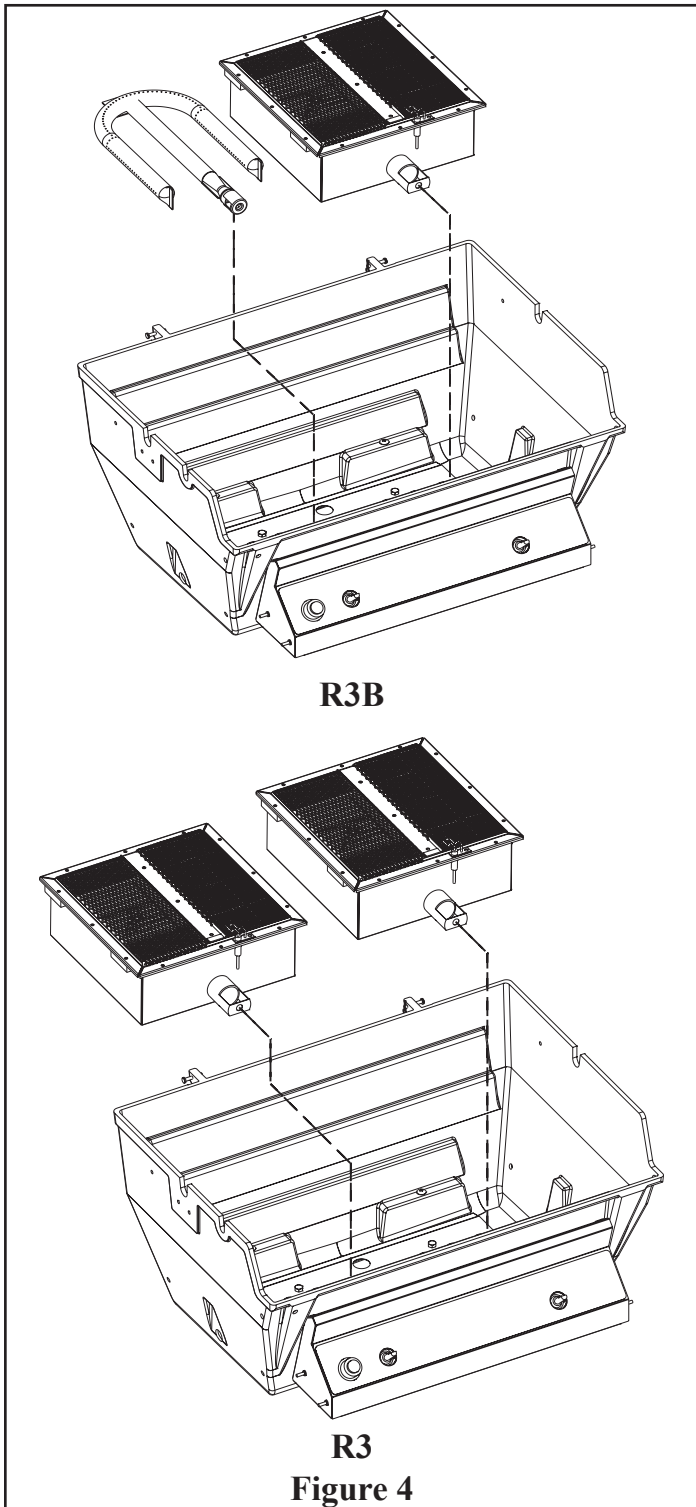

# GRILL ASSEMBLY

- Remove ignitor from the control panel by unscrewing the ignitor button and nut. Attach ignitor wires to terminals on the ignitor. See Figure 7.

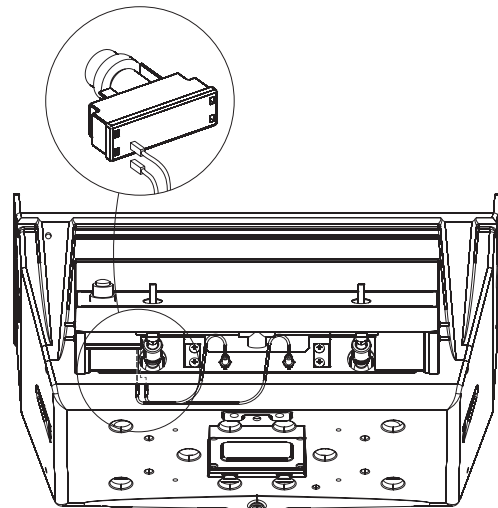

Figure 7

- Re-attach the ignitor to the control panel, then tighten nut and insert AA battery, positive side down, and replace ignitor button. See Figure 8.

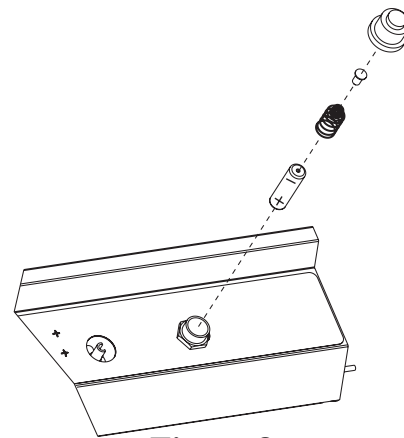

Figure 8

- Install foam grip (4) on lid handle (3). See Figure 9. **Tip:** For ease of installation, slightly lubricate the lid handle with liquid soap before pushing the foam grip into place.

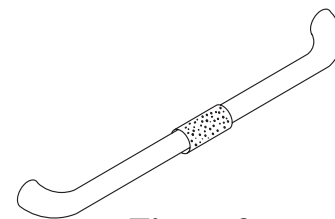
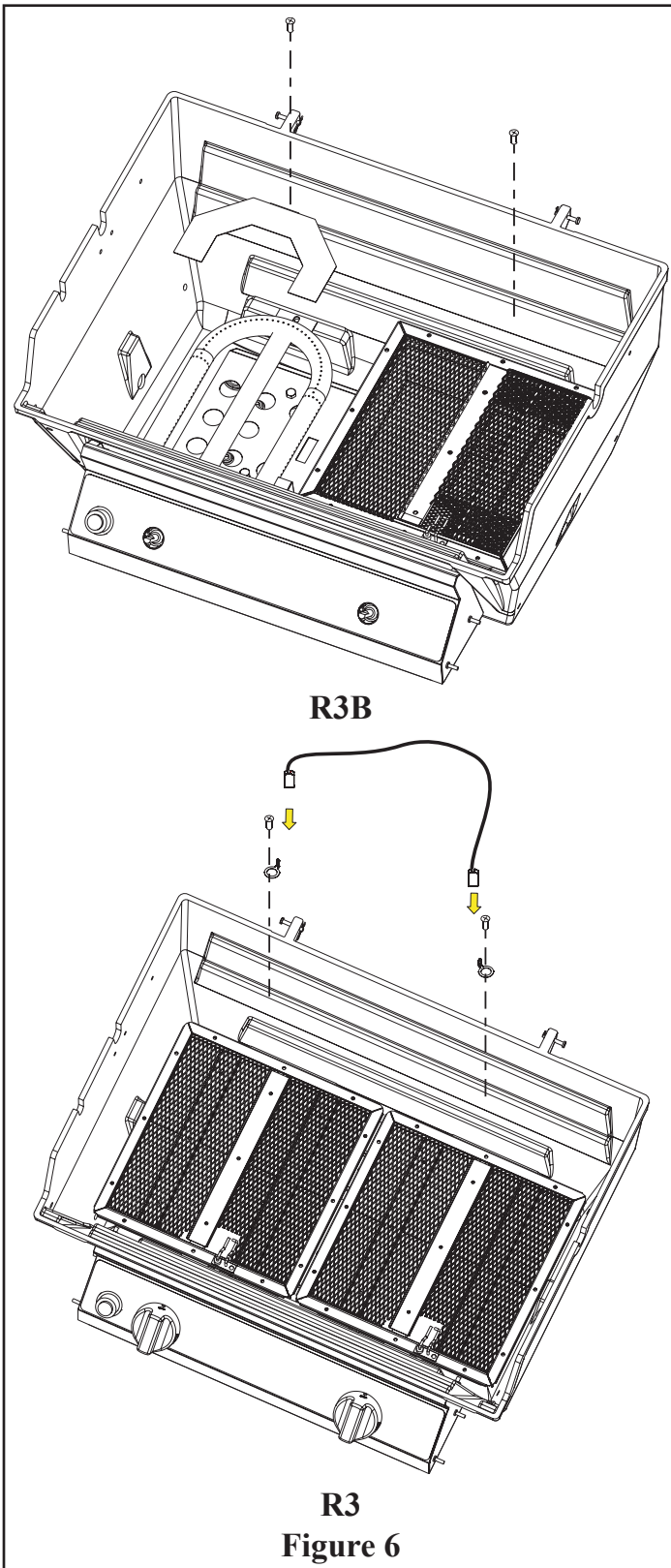
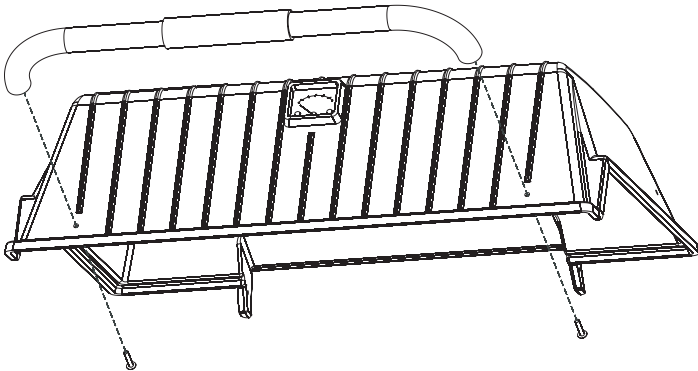

Figure 9



# GRILL ASSEMBLY

9. Fasten the lid handle to the grill body top (1) with two #10-24 x 1" screws. See **Figure 10**.



**Figure 10**

10. R3B models only: Place the briquet rack (7) over the blue flame burner only. See **Figure 11**.
11. R3B models only: Position the Char-Master briquet evenly on the briquet rack without overlapping. See **Figure 11**.

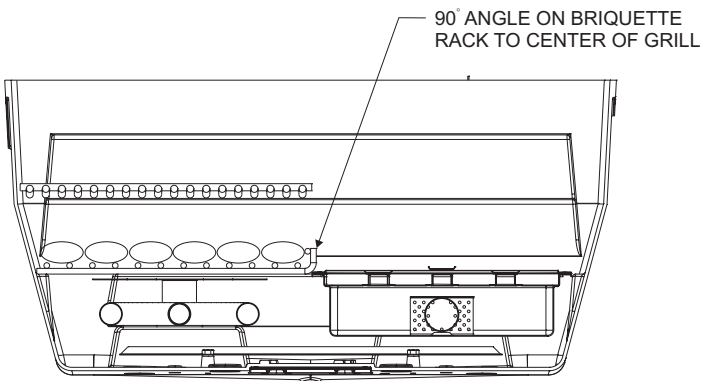
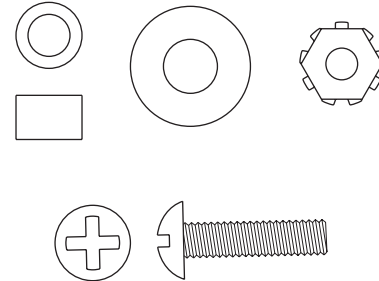

**Figure 11**

12. Set the cooking grids (6).
13. Push valve knobs (22) on to valves.

## Lid Stop

Attach the lid stop assembly to the grill bottom as shown. Figure 12.



**Lid stop assembly hardware**

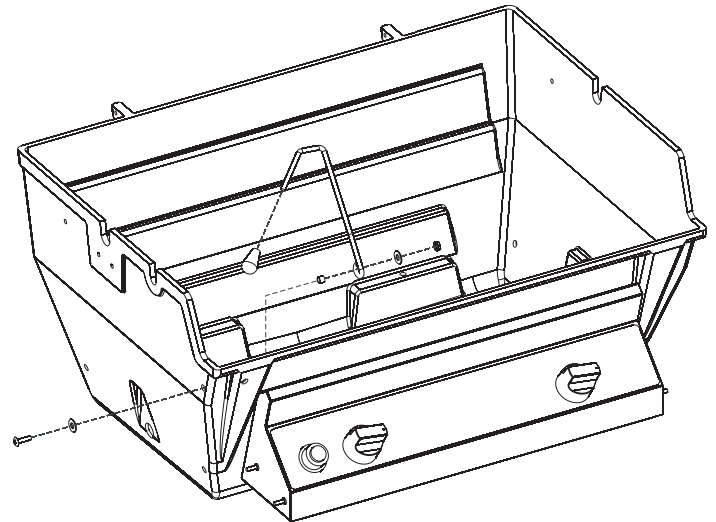

**Figure 12**

# PROPANE GAS GRILLS

## Grill Location

When choosing the ideal location for your Broilmaster Premium Gas Grill, remember this grill is designed for outdoor use ONLY.

You should never install or operate your grill in any building, garage, or other enclosed area.

For your safety, this grill should not be installed or operated under any combustible materials, such as carports, covered porches, awnings, or overhangs.

Never install or operate your grill in or on any recreational vehicle or boat.

**CAUTION: The installation and operation of this grill at clearances less than specified below may lead to the possibility of fire, property damage, or personal injury.**

A minimum clearance of sixteen (16") inches is required from the sides of the grill to any combustible material.

A minimum clearance of eighteen (18") inches is required from the back of the grill to any combustible material.

Some examples of combustible materials are a wall, a fence, patio furniture, or the wall of your home.

The area surrounding the grill should be clear to ensure proper ventilation. Do not obstruct the flow of combustion and ventilation air in any way. The ventilation openings on the propane cylinder enclosure must also remain free and clear of debris.

Portable grills should be level and positioned away from direct wind prior to each use.

**WARNING: Do not install or operate this grill where gasoline or other flammable materials are used or stored. Failure to comply with this warning could result in explosion or fire causing property damage or personal injury.**

## Gas Type

Never use Liquid Propane (LP) gas with a grill designed for Natural gas, or Natural gas with a grill designed for Liquid Propane gas. The type gas required for your grill can be determined from the product identification label located on the grill's control panel. Questions regarding different types of gases should be directed to your gas supplier.

## Cylinder Requirements

Your Broilmaster Premium Gas Grill requires a standard twenty (20) pound propane gas cylinder.

The maximum height allowable for a replacement cylinder is approximately twelve (12") inches (30.5 centimeters).

The propane gas cylinder used must be:

1. Constructed and marked in accordance with the specifications for LP gas cylinder of the U.S. Department of Transportation (D.O.T.) or the National Standard of Canada, CAN/CSA-B339, Cylinders, Spheres, and Tubes for Transportation of Dangerous Goods; and Commission as applicable.
2. Provided with a listed overfilling protection device (OPD).
3. Provided with a listed safety device having direct access with the vapor space of the cylinder and the cylinder supply system must be arranged for vapor removal.
4. Provided with a shutoff valve terminating in a valve outlet as specified in the Standard for Compressed Gas Cylinder Outlet and Inlet Connections, ANSICGA-V-1.
5. Provided with a plug to effectively seal off the cylinder outlet when the cylinder is being stored or transported.
6. Provided with a collar to protect the cylinder valve.

**Caution: Do not use a propane gas cylinder which has a capacity greater than twenty (20) pounds with this grill and side burner.**

# PROPANE GAS GRILLS

## Propane Cylinder Safety

Liquid Propane (LP) gas has a long history of safe use when the safety precautions provided in this manual are followed.

**Failure to follow these safety precautions could result in a fire or explosion causing property damage or personal injury.**

Propane gas cylinders should always be handled, stored, and transported with extreme caution in a secured upright position.

Never attempt to use or repair a propane gas cylinder that has been damaged. Never attempt to use or repair a cylinder with a faulty or damaged valve outlet. A cylinder that has been dropped, dented, or otherwise damaged must be replaced.

A propane gas cylinder should never be transported in the passenger area of a vehicle.

Keep cylinders out of direct sunlight and never apply any other source of direct heat to them.

When refilling your cylinder, always insist on a reputable, qualified gas dealer. Your propane gas cylinder is filled by weight, and should never exceed eighty (80%) percent of its weight limit. If the cylinder is not completely empty, the gas dealer must make necessary adjustments to ensure it is not overfilled. Never use an overfilled Propane gas cylinder.

## Cylinder Storage

Your grill must be stored outdoors in a well ventilated area if the cylinder is attached to it.

Disconnected cylinders must have a threaded valve plug tightly installed and must not be stored in any building, garage, or other enclosed area.

Flammable materials (gasoline, grill covers, etc.) must not be stored in the cylinder enclosure.

Always store Propane cylinders in a secured upright position, out of the reach of children.

## Connection Requirements

**Caution: Never use Liquid Propane (LP) gas in a grill designed for Natural gas, or Natural gas in a grill designed for Liquid Propane gas. Questions regarding different types of gases should be directed to your local gas supplier.**

Installation must conform to local codes or in the absence of local codes, with the National Fuel Gas Code, ANSI Z223.1/NFPA 54, Natural Gas and Propane Installation Code, CSA B149.1, or Propane Storage and Handling Code, B149.2.

**Warning: Broilmaster Premium Gas Grills require Liquid Propane (LP) cylinders equipped with an Overfill Protection Device (OPD). An overfilled or improperly filled Propane cylinder can be dangerous.**

Always use the pressure regulator and hose assembly supplied with your Propane gas grill.

Note: Not all valve and cylinder combinations are compatible. Check warning tag on valve and cylinder as well as external fitting threads.

All Broilmaster pressure regulators and hose assemblies require Propane cylinders with a Type 1 connection device as illustrated. See Figure 13.

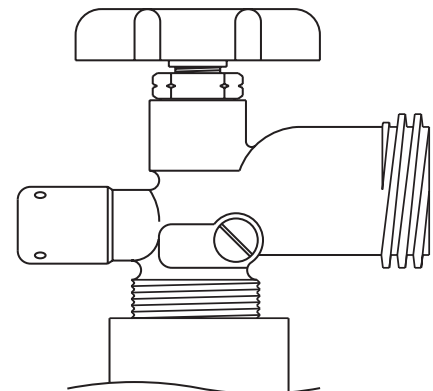

Figure 13

# PROPANE GAS GRILLS

## Pressure Regulator and Hose Assembly

The pressure regulator has an outlet pressure of not more than eleven (11") inches water column. It must be connected to the Propane gas cylinder's male valve outlet before the grill can be operated.

**Caution: Operation of a Propane gas grill without the pressure regulator and hose assembly will cause gas leaks which could lead to fire or explosion, resulting in property damage or personal injury.**

The pressure regulator's fitting must remain clean and free of nicks and scratches. A dirty, nicked or scratched fitting can cause a gas leak, resulting in an explosion or fire. Use only genuine Broilmaster replacement parts unless otherwise specified by the manufacturer.

## Connecting to Propane Gas / Cylinder Retention Means

Position the cylinder in the opening in the bottom of the cart and secure with the cylinder retaining bracket. See Figure 14.

Attach the pressure regulator to the Propane gas cylinder's valve using the plastic handwheel. Tighten in a clockwise motion to achieve a gas tight seal. See Figure 15.

**Caution: Do not use a wrench or any other tool to tighten. Use of a wrench or other tool will damage the plastic handwheel.**

To disconnect the Propane gas cylinder, turn OFF the cylinder's valve and the grill's control valve. Remove the regulator by turning the plastic handwheel counterclockwise.

**When not in use, the cylinder's valve must be closed.**

**Attention:** Propane gas cylinders that are acceptable for use with this grill must comply with "Cylinder Requirements" section and "Connection Requirements" section.

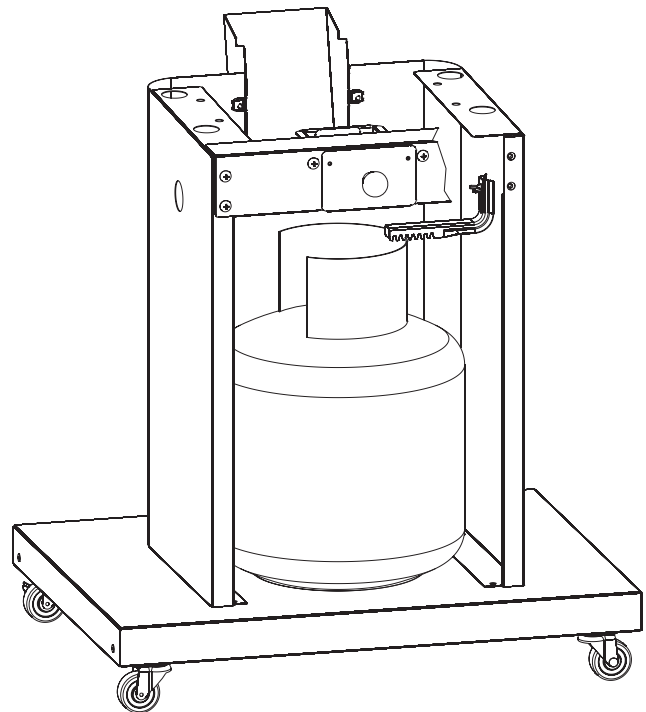

Figure 14

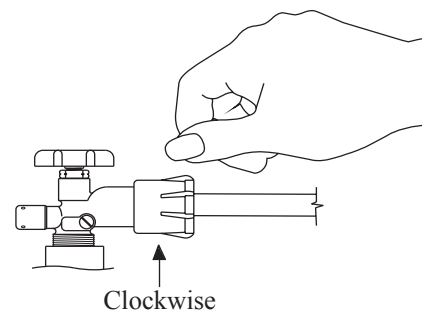
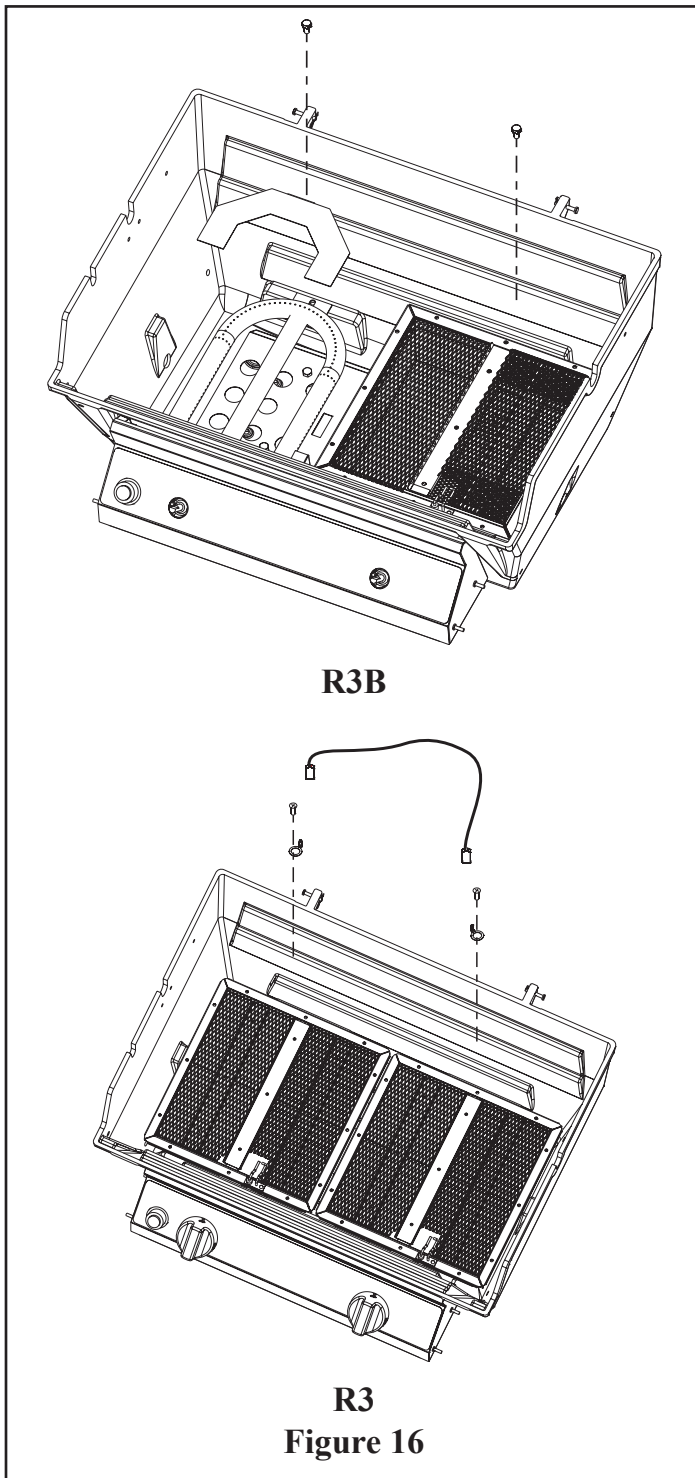

Figure 15



# GAS CONVERSION TO NATURAL GAS

1. R3B Grills: Remove cooking grids, briquets and briquet rack from grill.
2. Blue Flame Burner: Remove blue flame burner shield and blue flame burner from grill (one (1) 1/4-20 x 3/4 phillips screw for burner). See Figure 16.  
Infrared Burner: Remove ignitor wire, lugs and infrared burner from grill (one (1) 1/4-20 x 3/4 phillips screw for each burner). See Figure 16.



3. Remove LP burner orifices marked 1.25 mm for R3B. Remove LP burner orifice marked 1.3 mm for R3. See Figure 17.

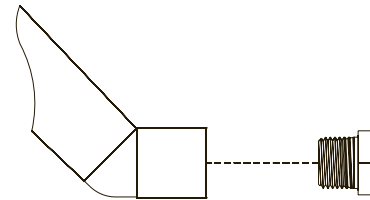

**Figure 17**

4. Install natural gas burner orifice marked 49 into each orifice fitting. Apply pipe compound to threads on orifices prior to installation.
5. Blue Flame Burner: Place burner shield and burners into grill and insert burner tubes over orifice fittings. Secure each burner with one (1) 1/4-20 x 3/4 phillips screw from Step 2.  
Infrared Burner: Place infrared burners, ignitor, and lugs into grill and insert burner tubes over orifice fittings. Secure each burner with one (1) 1/4-20 x 3/4 phillips screw from step 2.
6. Grasp valve knobs and remove from valves.
7. The low input adjustment screws are located inside the two valve stems. Use a small screwdriver to turn each adjustment screw clockwise 1/4 turn (90 degrees). When valves are in the "OFF" position, the slot in the adjustment screw should be vertical. See Figure 18.

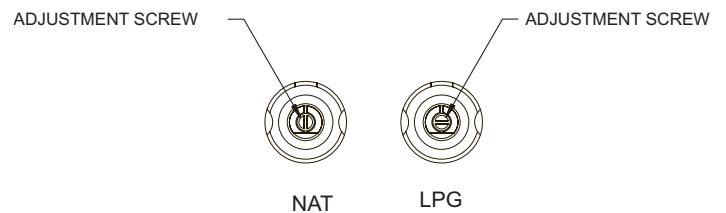

**Figure 18**

8. Remove the hose and regulator from the gas connection on grill with adjustable wrench.
9. Connect the grill to the natural gas supply.  
**Attention:** Before lighting your grill check all gas connections including the adjustment screws in valve stems for gas leaks with a soapy water mixture.  
**Caution:** Do not use the grill if a gas leak is detected until gas leak is corrected. If a gas leak can not be stopped, do not use grill. You must contact a qualified repair person.
10. Push valve knobs onto valves.
11. Apply the completed conversion label adjacent to the rating plate label on the grill.

# GAS CONVERSION TO NATURAL GAS

12. The natural gas inlet pressure at the grill is to be set at 7.0" of inlet pressure.
13. Ignite burner on grill and observe flame pattern. If flame is yellow in color or flame is lifting off burner, the air shutter on blue flame burners only will require adjustment.
14. Beneath the control panel you can access the air shutter which is located on the end of the burner tube.
15. Loosen phillips screw at air shutter, open air shutter for a yellow flame or close air shutter for a lifting flame. Tighten phillips screw at air shutter.
16. Ignite burners on grill to verify burner flame characteristics.
17. Replace briquet rack and briquets and reinstall cooking grids.

Installation must conform to local codes or in the absence of local codes, with the National Fuel Gas Code, ANSI Z223.1/ NFPA 54, Natural Gas and Propane Installation Code, CSA B149.1, or Propane Storage and Handling Code, B149.2.

**Caution: The grill and its individual shutoff valve must be disconnected from the gas supply piping system during any system pressure testing at test pressures in excess of 1/2 PSIG.**

**Caution: The grill must be isolated from the gas supply piping system by closing its individual manual shutoff valve during any pressure testing of the gas supply piping system at test pressures equal to or less than 1/2 PSIG.**

# NATURAL GAS GRILLS

## Grill Location

When choosing the ideal location for your Broilmaster Premium Gas Grill, remember this grill is designed for outdoor use ONLY.

You should never install or operate your grill in any building, garage, or other enclosed area.

For your safety, this grill should not be installed or operated under any combustible materials, such as carports, covered porches, awnings, or overhangs.

Never install or operate your grill in or on any recreational vehicle or boat.

**CAUTION: The installation and operation of this grill at clearances less than specified below may lead to the possibility of fire, property damage, or personal injury.**

A minimum clearance of sixteen (16") inches is required from the sides of the grill to any combustible material.

A minimum clearance of eighteen (18") inches is required from the back of the grill to any combustible material.

Some examples of combustible materials are a wall, a fence, patio furniture, or the wall of your home.

The area surrounding the grill should be clear to ensure proper ventilation. Do not obstruct the flow of combustion and ventilation air in any way. The ventilation openings on the propane cylinder enclosure must also remain free and clear of debris.

Portable grills should be level and positioned away from direct wind prior to each use.

**WARNING: Do not install or operate this grill where gasoline or other flammable materials are used or stored. Failure to comply with this warning could result in explosion or fire causing property damage or personal injury.**

## Gas Type

The type gas required for your grill can be determined from the product identification label located on the grill's control panel. Questions regarding different types of gases should be directed to your local gas supplier.

**Caution: Never use Liquid Propane (LP) gas in a grill designed for Natural gas, or Natural gas in a grill designed for Liquid Propane gas. Questions regarding different types of gases should be directed to your local gas company.**

## Connection Requirements

Broilmaster grills are not equipped with pressure regulators. Your gas grill operates at a manifold pressure of seven (7") inches water column.

Connect cart mounted Natural gas grills to a pre-installed gas supply line using the twelve (12') foot flexible hose and quick disconnect kit which can be purchased from your local dealer.

## Hazardous Locations and Conditions

- The LP gas cylinder must be arranged upright for vapor withdrawal.
- Do not obstruct the flow of combustion and ventilation air.
- This grill should only be used outdoors in a well-ventilated space must not be used in a building, garage, or any other enclosed area.
- Keep all flammable substances away from the grill. These include most aerosols and aerosol containers, gasoline and similar liquids, paper and paper products, containers of grease, paint, etc.
- Never store flammable materials or objects such as those described above in the pedestal base.
- Never leave grill unattended while in operation.
- Never use any liquid in an attempt to control flare-up.
- It may be necessary to adjust your grill away from the direction of prevailing wind.
- Avoid wearing flammable and/or loose clothing such as long-sleeves, neckties, scarves, aprons, etc., while the grill is in operation.
- Avoid contact of hair to heat and flames.

# INFRARED COOKING

## General Overview

Broilmaster Infrared gas grills make it possible for you to enjoy cooking outdoors quickly and effortlessly. In minutes, you can enjoy steaks, hamburgers, poultry, pork chops, fish and other foods. You can also cook more slowly if you wish. Broilmaster's optional accessories are designed to enhance your grill's versatility.

## Infrared Searing Method

Searing is a process that seals juices in food by cooking with intense heat for a short period of time. The juices stay in the food where they belong and the outside gets coated with flavorful smoke. For best results, follow these procedures when cooking.

## Searing Method

1. Follow the Burner Ignition procedures and operate the grill for 5 minutes or until the burners glow uniformly.
2. Set the Burner Output Knob to HIGH and place the food on the cooking grid for 1 - 2 minutes, or until food lifts without sticking.
3. Turn the food and repeat Step 2.
4. Depending upon your taste, continue cooking on HIGH, turning the food frequently, or adjust the Burner Output Knob to a setting between LOW and "medium" and continue cooking until the food is cooked to your satisfaction. Turn as necessary (generally every one to three minutes).

During the searing period, flashing might occur when juices vaporize on contact with the cooking grid and burner surfaces. The flashes and smoke greatly enhance the flavor of food.

The intense infrared energy generated by your Broilmaster Grill has other advantages. For example, food is evenly cooked throughout. Also, upon contact with the cooking grids and burners, drippings vaporize into flavorful smoke that cooks back into the food.

## Flare-Up Control

**NOTICE: NEVER DOUSE A FLARE-UP WITH LIQUID. IT WILL DAMAGE THE BURNER AND VOID THE WARRANTY!**

To minimize flame flare-ups:

- Trim excess fat from meat.
- Reduce heat and reposition foods away from flare-ups when they occur.
- Prevent excess grease build up by periodically cleaning cooking grids.

## Helpful Hints

1. Use the proper tools. Long handled tongs, spatula, knife, and mitts or a hot pad for handling hot items. When turning or moving foods, use tongs or a spatula, instead of a fork. Piercing the food with a fork allows the natural juices and flavor to escape.
2. Monitor meat temperature. Bring large cuts of meat, roasts, or fowl to room temperature before cooking. Smaller meat cuts such as hamburgers, hot dogs, or small steaks may be cooked directly from the refrigerator. Note: Broilmaster does not recommend cooking portion meats from a frozen state.
3. Start slowly. Infrared grilling is unlike other outdoor cooking methods. It may take time to get used to the fast cooking process. As a benchmark, foods which generally cook in 20 minutes or less on conventional grills cook in about one-half the conventional time on a Broilmaster infrared grill. Please refer to the Infrared Cooking Sample Times on page 21.

## Indirect Cooking with a Broilmaster Infrared Grill

Indirect cooking is a slower process used to prepare large main dishes - roasts, hams, turkeys, etc. Foods are placed on one side of the grill and the other side is lighted to produce heat.

To protect the infrared burner from damage, place a heavy-duty disposable aluminum pan over the burner to catch drippings. **Note:** Make sure the aluminum pan is the same size or larger than the infrared burner. Any liquids that land on the burner while it is not burning may cause it to break when ignited.

The pan may be filled part-way with liquid (water, marinade, etc.) to enhance the moisture content of the meat, but take special care not to spill anything onto the burner when adding liquids or when removing the pan after cooking.

# INFRARED COOKING SAMPLE TIMES & GRID POSITIONS

FOOD	FOOD "DONENESS"			APPROXIMATE COOKING TIME WITH INFRARED
	COOKING GRID POSITION 1	COOKING GRID POSITION 2	COOKING GRID POSITION 3	
Steak Pieces- 1" Thick	Medium Rare	Medium/Medium Rare	Rare	4 Minutes, 2 minutes per Side
	Medium	Medium Rare	Medium Rare	6 Minutes, Turn every 2 minutes
	Well	Medium Well	Medium	8 Minutes, Turn every 2 minutes
	Not Recommended	Not Recommended	Well	10 Minutes, Turn every 2 minutes
Steak - 1" Thick	Rare	Medium Rare	Rare	4 Minutes, 2 minutes per Side
	Medium Well	Medium Well	Medium	8 Minutes, Turn every 2 minutes
	Well	Well	Medium Well	10 Minutes, Turn every 2 minutes
	Not Recommended	Not Recommended	Well	12 Minutes, Turn every 2 minutes
Pork Chops	Well	Medium Well	Medium Well	6 Minutes per Side
	Not Recommended	Well	Medium Well	7 Minutes per Side
	Not Recommended	Not Recommended	Well	8 Minutes per Side
Hot Dogs	Done	Not Recommended	Not Recommended	3 Minutes, Turn as Needed
	Not Recommended	Done	Not Recommended	4 Minutes, Turn as Needed
	Not Recommended	Not Recommended	Done	4 to 6 Minutes, Turn as Needed
Shrimp - 20 to 30 count	Done	Not Recommended	Not Recommended	3 Minutes, Turn as Needed
	Not Recommended	Done	Not Recommended	4 Minutes, Turn as Needed
	Not Recommended	Not Recommended	Done	5 Minutes, Turn as Needed
Beef Kabob - 1 1/2" Meat Cubes	Not Recommended	Done	Not Recommended	12 Minutes, 1/3 turn every 2 minutes
Hamburger - 1" Thick	Not Recommended	Done	Not Recommended	14 Minutes, Turn every 2 minutes
	Not Recommended	Not Recommended	Done	16 Minutes, Turn every 2 minutes
Hamburger - 1/2" Thick	Medium Well	Medium/Medium Well	Medium	7 Minutes, Turn every 2 minutes
	Well	Well	Medium Well	9 Minutes, Turn every 2 minutes
	Not Recommended	Not Recommended	Well	11 Minutes, Turn every 2 minutes

# INFRARED COOKING SAMPLE TIMES & GRID POSITIONS

FOOD	FOOD "DONENESS"			APPROXIMATE COOKING TIME WITH INFRARED
	COOKING GRID POSITION 1	COOKING GRID POSITION 2	COOKING GRID POSITION 3	
Boneless Chicken Breast - 3/4" Thick	Done	Not Recommended	Not Recommended	14 Minutes, Turn over every 2 minutes
	Not Recommended	Done	Not Recommended	16 Minutes, Turn over every 2 minutes
	Not Recommended	Not Recommended	Done	18 Minutes, Turn over every 2 minutes
Chicken Breast - Bone In	Not Recommended	Not Recommended	40 Minutes (Low)	Turn as Needed
Chicken Legs - Bone In	Not Recommended	15 Minutes (Low)	20 Minutes	Turn as Needed
Chicken Wings - Bone In	Not Recommended	15 Minutes (Low)	20 Minutes	Turn as Needed
Spare Ribs	Not Recommended	Not Recommended	Preferred Position	8 Minutes per Side on High, Turn every 4 minutes

Cooking temperature setting is on HI unless otherwise specified.

Marinades and rubs will cause flare-ups. Use caution with cooking foods seasoned in this manner.

Caution: Under-cooked and raw meat can cause serious illness. Cook all meats to USDA recommended internal temperatures.

Cooking times are provided as guideline only. For the best results use a high quality instant-read out thermometer and follow the USDA recommended temperatures ([www.usda.gov](http://www.usda.gov) keyword "Is it done yet?").

**NOTICE: NEVER DOUSE A FLARE-UP WITH LIQUID. IT WILL DAMAGE THE BURNER AND VOID THE WARRANTY!**

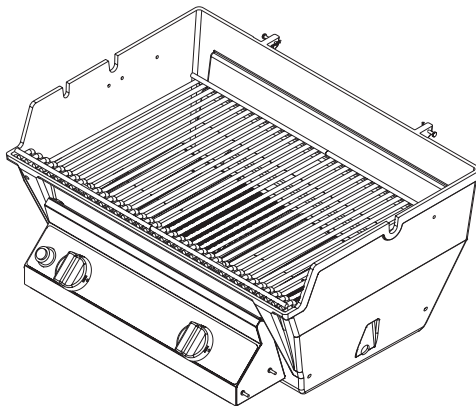

Cooking Grid Position 1

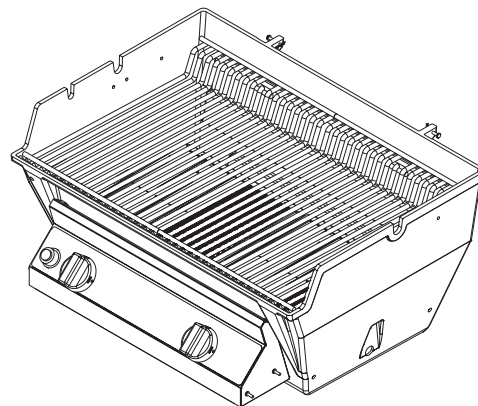

Cooking Grid Position 2

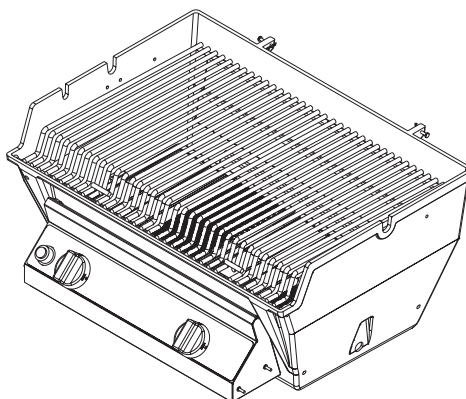

Cooking Grid Position 3

# OPERATION - PROPANE & NATURAL GAS GRILLS

## Checking for Gas Leaks

Check for gas leaks every time you connect your Broilmaster propane gas grill to a Propane gas cylinder, when a connected cylinder has not been used recently, or when either a natural or propane grill is being used for the first time.

**Caution: Do not use an open flame when checking for leaks. Checking for leaks with an open flame may lead to a fire or explosion, resulting in property damage or personal injury.**

To check for gas leaks:

1. Use dish washing liquid and a little water to make a soapy solution.
2. Turn OFF the knob on the control panel.
3. Turn ON the gas at the supply or cylinder. A hissing sound indicates a leak. Turn OFF the gas and repair the leak.
4. Apply the soapy water solution to all gas connections.
5. Look for bubbles. Bubbles indicate a leak.
6. If there are bubbles turn OFF the gas and repair the leak.
7. Turn the gas back ON and repeat the above procedures until all leaks are repaired.

## Air Shutter Adjustment For R3B Series Only

The burner (venturi) tube air shutter is preset at the factory so that after five minutes the burner flames are blue with well defined cones. If, after five minutes the flame is yellow, or there is a gap between the burner and the flame, adjust the burner (venturi) tube air shutter as follows:

1. Turn gas OFF and let the burner cool.
2. Beneath the control panel you can access the air shutter(s) which are located on the end of the burner tubes.
3. Loosen shutter set screw
4. Close the air shutter to the minimum opening.
5. Light the burner, wait five minutes and then carefully open the air shutter until the flame is blue and well defined.
6. Retighten the set screw.

## Operating Instructions

Before each use, inspect all hoses. If it is evident there is excessive abrasion or wear, or the hose is cut, it must be replaced prior to using your Broilmaster grill. Call your local Broilmaster dealer for a replacement.

### Using the Ignitor

**Caution: If a burner fails to light after 5 seconds, turn the burner OFF for 5 minutes, to allow the gas to clear, then try again.**

**Note: Each burner must be lit individually.**

1. Turn knob on the grill CLOCKWISE to the OFF position.
2. Turn ON gas at the source.
3. With the grill lid open, push and turn the burner control knob COUNTERCLOCKWISE to HI.
4. Push and hold the ignitor button until the burner lights (approximately 5 seconds).
5. If a burner does not light, turn OFF all gas and refer to the Troubleshooting section of this manual.
6. Repeat steps 3 through 5 for other burner.

## Using Matches to Light the Grill

**Caution: If a burner fails to light after 5 seconds, turn the burner OFF for 5 minutes, to allow the gas to clear, then try again.**

**Note: Each burner must be lit individually.**

1. Turn knob on the grill CLOCKWISE to the OFF position.
2. Turn ON gas at the source.
3. Open the grill lid.
4. For Blue Flame grills, insert a burning long wooden match through the lighter hole on the left side of the grill. For Infrared grills, insert the lighting stick with a long wooden match attached through the cooking grid to ignite the infrared burner from the top. **See Figure 19.**
5. Turn the burner control knob COUNTERCLOCKWISE to HI.
6. If a burner does not light, turn OFF all gas and refer to the Troubleshooting section of this manual.
7. Repeat steps 3 through 6 for other burner.

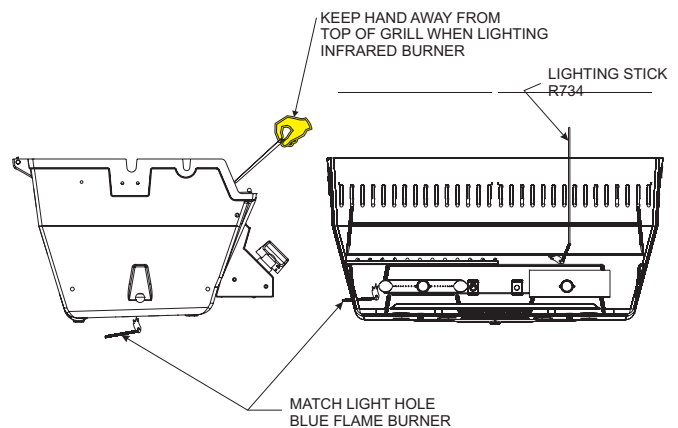

**Figure 19**

# OPERATION - PROPANE & NATURAL GAS GRILLS

## Before Cooking

Before cooking on a grill for the first time, it should be operated to burn off any oil residue from the manufacturing process.

1. Raise the grill lid.
2. Light grill burners.
3. Burn on HI for ten minutes.
4. Close the lid and burn on HI for an additional ten minutes.
5. Turn OFF gas. The grill is now ready for use.

## Preheating

Before cooking on a gas grill, allow the grill to preheat on HI for 5 minutes with the lid open.

This uses very little fuel and provides better flavor.

### **WARNING!**

**HOOD MUST BE OPEN WHEN LIGHTING GRILL BURNERS, WARMING UP THE GRILL, AND WHILE GRILLING. HOOD MAY ONLY BE CLOSED WHILE INFRARED IS IN USE AND BOTH KNOBS ARE SET ON "LOW," OR WHILE BLUE FLAME BURNER IS IN USE ONLY, OR WHEN THE GRILL IS NOT IN USE.**

### **AVOID WATER DAMAGE TO BURNER!**

**NEVER ALLOW WATER TO CONTACT THE BURNER AS DAMAGE WILL RESULT. WATER DAMAGE IS NOT COVERED BY YOUR BROILMASTER WARRANTY.**



# BLUE FLAME BURNER MAINTENANCE

## Cleaning the Grill

**Caution:** To prevent injury, do not clean a hot grill.

**Note:** Do not use a commercial cleaner on the cooking grids. Do not brush grids while they are hot.

For baked on residue use a BRASS (NOT STEEL) brush on the cooking grid and other components.

## Burn Off

This process is much like that used in self-cleaning ovens and is most efficient when completed after each use of the grill.

**Caution:** Do not open the grill during the burn off process. Opening the grill during the burn off process may cause a sudden grease fire flare up that could burn your face and arms. Wait until the grill has cooled before opening.

1. Turn gas knob to HI. Close lid and allow the grill to burn for ten minutes, or until no smoke is present. Do not allow the grill to burn for more than 30 minutes.
2. Turn gas knob and supply to OFF and allow the grill to cool.
3. Wipe COOL grill with a damp cloth to remove soot.

## Grill Bottom

Periodically remove cooking grids and Char-Master Briquets or flavor screen to clean the interior of the grill. Scrape off baked on residue with a putty knife or brass brush and rinse with water. Clean the bottom air holes with a small knife.

## Blue Flame Burner Maintenance

Visually inspect the burner flames with each use. Five minutes after lighting, the flames should be blue and have well defined cones. See Figure 20. See the troubleshooting section if the flames are yellow or lift off the burner.

Stainless steel burners often turn reddish brown after use. This does not effect the performance of the grill. When cleaning the interior of the grill, remove the burners and clean with a brass brush. Wash with water and a mild detergent.

## Grease Tray

Empty periodically. Replacement tray liners can be purchased at most supermarkets where disposable aluminum baking pans are displayed.

## Burner (Venturi) Tubes

The burner (venturi) tubes allow air and gas to mix prior to burning, thus ensuring an efficient flame. Spiders or other small insects may build webs or nests inside the tubes obstructing air flow. Fire, or flashback, can occur, in and/or around obstructed burner (venturi) tubes and can cause damage to components beneath the grill or an unsafe condition. To reduce risk, inspections and cleaning should be performed at least twice monthly when spiders are active. If the grill has been unused for an extended period of time inspect the tubes before using the grill.

### Clean burner (venturi) tubes as follows:

1. Remove the cooking grids and briquet rack (R3B only).
2. Remove the burner from the grill.
3. Use a small flexible brush to remove any debris from the burner (venturi) tube.
4. Flush with water.
5. Allow the burner (venturi) tube to dry before reinstalling.
6. Reinstall the burner, briquet rack and briquets and cooking grids.

## Exterior

Clean regularly with a solution of mild detergent and hot water. Touch-up paint is available from your dealer. Broil-master protective covers are recommended. Stainless steel components can be easily cleaned with a spray-on stainless steel cleaner found in most hardware stores.

## Char-Master Briquets

If the briquets did not come clean during burn off, after cooling turn them over. The residue will burn off during warm-up for the next use.

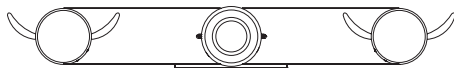

Correct Flame Pattern

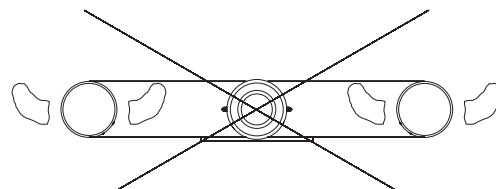

Incorrect Flame Pattern

Figure 20

# INFRARED BURNER MAINTENANCE

## General Overview

Proper care, maintenance and cleaning will help ensure a long life for your grill. Periodic cleaning will help avoid accumulations of flammable grease and other debris.

## Exterior

Clean regularly with a solution of mild detergent and hot water. Touch-up paint is available from your dealer. Broil-master protective covers are recommended. Stainless steel components can be easily cleaned with a spray-on stainless steel cleaner found in most hardware stores.

## Protection of Burners

The burners of your grill are designed to provide a long life of satisfactory performance. However, there are steps you must take to prevent cracking of their ceramic surfaces, which will cause the burners to malfunction. Following are the most common causes of cracks and the steps you must take to avoid them. Damage caused by failure to follow these steps is not covered by your grill warranty.

**IMPACT WITH HARD OBJECTS** - Never allow hard objects to strike the ceramic. Take particular care when inserting or removing the cooking grids and accessories into or from the grill. If objects such as these fall onto the ceramic, it is likely to crack the ceramic.

**IMPAIRED VENTILATION OF HOT AIR FROM THE GRILL** - In order for the burners to function properly, hot air created by the burners must have a way to escape the grill. If the hot air is not allowed to escape, the burners may become deprived of oxygen, causing them to backfire, especially if the burner output is set at HIGH. If this occurs repeatedly, the burners may crack. Never operate your grill with very little or no open space at the cooking surface (the cooking grids provide sufficient open space.

Examples:

- DO NOT operate the grill on "HIGH" with the hood closed.
- DO NOT use accessories in combinations that cover more than 75% of the cooking surface with solid metal.
- DO NOT cover the entire surface with aluminum foil, a large pan, etc.

**WATER AND OTHER LIQUIDS** - When the burners are in operation, their intense heat is normally sufficient to vaporize any drippings, marinates or sauces that contact the surface as a by-product of grilling. This does not include water thrown into the grill to douse a flame. Cold liquid contacting a hot

surface in substantial amounts can cause the surface to break. Also, if the ceramic or interior of a burner becomes wet while not in use, later operation of the burner can create steam, which may produce enough pressure to crack the ceramic. In addition, repeated soaking of the ceramic will cause it to swell and expand. This expansion will create pressure on the ceramic and cause it to crack and crumble.

To prevent burner damage caused by liquids, please do the following:

- Never throw liquid into the grill to control a flare-up.
- Never expose the burners to the risk of soaking by rainfall, sprinklers or otherwise. We recommend that the grill be covered with a heavy duty vinyl cover at all times when it is not in use. Do not attempt to operate your grill in the open air while it is raining. Finally, using the grill, close the hood as soon as the burners are off so that, if it rains, the burners will not be exposed to direct rainfall while the grill is cooling.
- If standing water is in the grill (because of exposure to rainfall, etc.) examine the ceramic burner surfaces for evidence of possible water soaking. If the ceramic appears to be wet, remove the burners from the grill and turn them upside down to empty any water from the burner box. After draining all the water, place the burners indoors and allow to dry thoroughly. Also, empty any water standing in the grill's drip tray. Then, reinstall the burners. After testing for gas leaks around all fittings, resume normal use of the grill.

## Cleaning

**CAUTION: ALWAYS ALLOW THE GRILL TO COOL BEFORE CLEANING. DO NOT LET LIQUIDS COME IN CONTACT WITH THE BURNER SURFACE AT ANY TIME.**

## Grease Tray

Empty periodically. Replacement tray liners can be purchased at most supermarkets where disposable aluminum baking pans are displayed.

## Cooking Grids

### Burn Off

This process is much like that used in self-cleaning ovens and is most efficient when completed after each use of the grill.

Because of the high intensity of the Infrared burner, any drippings and food particles that fall onto the burner sur-

# INFRARED BURNER MAINTENANCE

face are immediately incinerated. However, some debris and residue may remain. To remove this residue after cooking, turn the grill on HIGH for 5-10 minutes with the hood OPEN.

## **Standard Cleaning**

The cooking grids may also be removed and cleaned with a brass or stainless steel bristle brush and soapy solution. Standard oven cleaners may be used for further cleaning. Rinse the cooking grids thoroughly with clean water before using.

## **Maintenance**

The Broilmaster requires very little maintenance. However, a periodic inspection of orifice openings and venturi inlets to clear obstructions to gas flow is recommended.

## **Burner Head**

To maintain the performance of the Infrared burner it is important to operate the grill on HIGH for at least 5 minutes after each use.

This procedure will leave some ash on the surface of the burner head. If it accumulates in excessive amounts, it will clog the small ports in the ceramic surface. To prevent this blockage, remove the cooking grid and the burner screen, and vacuum the burner surface with a low-suction vacuum cleaner every six months, or as necessary. When completing this procedure be careful not to scrape or strike the ceramic with the suction device, which may damage the ceramic.

# TROUBLESHOOTING

Although the manufacturer has attempted to ensure that your grill will operate properly and satisfactorily, sometimes problems do arise. The following troubleshooting guide lists several possible problems and their probable cause and solution.

<b>Problem</b>	<b>Cause</b>	<b>Solution</b>
Burner will not light.	Gas injector not inserted in venturi tube.	Realign/engage gas injector with the venturi tube.
	Clogged gas injector.	Remove gas injector from gas control assembly and clean.
	Obstruction in gas line.	For propane models, ensure gas valve on cylinder is OFF. Remove flexible hose and blow out any debris.
	Spider webs in venturi tubes.	Clean venturi tubes. See Maintenance Section.
	Misalignment of collector box and burner.	Position electrode properly. Clean collector box.
	Out of gas.	Refill LP gas cylinder. If natural model, turn on gas at source.
Inadequate grill temperature.	Dead battery.	Replace with AA Alkaline battery.
	Poor combustion.	Adjust air shutter.
	Misalignment of venturi tube and gas injector.	Realign/engage gas injector with the venturi tube.
	Inadequate gas pressure.	Contact gas supplier for assistance.
Flames off the burner.	Incorrect orifice/valve setting.	Refer to gas conversion instructions in this manual.
	Cold grill.	Preheat grill at least 5 minutes on HI with the grill lid open.
	Misalignment of burner tube and gas injector.	Realign/engage gas injector with the burner tube.
	Poor combustion.	Adjust air shutter.
Yellow flames.	Extreme wind.	Turn or shield grill.
	Air shutter improperly set.	Open air shutter.
	Spider webs in venturi tubes.	Clean venturi tubes. See Maintenance Section.
	Seasoning salts on burner.	Clean by washing burner with mild detergent.
Low heat with knob in "High" position.	Oil film on burner.	Allow burner to operate on HI for 10-15 minutes.
		Check for proper gas supply and pressure.
		Pre-heat grill for a full 15 minutes.
		If using L.P. gas, check for empty tank.
		Check for kinks in supply line.
Infrared back burner won't light.		If only one burner appears low, clean burner, clearing ports of any obstructions.
		Check the burner inlet for obstructions.
		Grill may be in a dusty area. Move to a less dusty area if possible.



# WARRANTY TERMS

The Most Durable Grill Known  
To Man

<b>Limited Lifetime</b>	<ul style="list-style-type: none"> <li>• Casting top and bottom (except paint)</li> <li>• Control panel, stainless steel fasteners, shelves, warming racks</li> <li>• Select stainless steel components - cart, mounting</li> <li>• Cast stainless steel cooking grids (Damage caused by dropping, scraping, or abrasive cleaning voids the warranty for cooking grids)</li> </ul>
<b>10 Years</b>	<ul style="list-style-type: none"> <li>• Stainless steel burner</li> </ul>
<b>Limited 5 Years</b>	<ul style="list-style-type: none"> <li>• Infrared burners (Damage caused by liquid voids the warranty for burners)</li> </ul>
<b>1 Year</b>	<ul style="list-style-type: none"> <li>• All other parts</li> </ul>

## What Is Covered And For How Long

From the date this Broilmaster Premium Gas Grill is first purchased, we will make available at our factory a free replacement for any defective part covered by this warranty on the following basis. Proof of purchase required. Warranty applies to original owner and is not transferable.

## What Is Not Covered

- Removal and reinstallation cost.
- Labor for replacement or repairs.
- The costs of a service call to diagnose a problem.
- Transportation and shipping cost.
- Surface corrosion.
- Grills and finishes damaged by abrasive cleaning, improper installation, improper storage, accident, misuse, abuse, alteration, commercial use, and unusually harsh environmental conditions. Harsh conditions could include, but are not limited to: continual seawater spray, direct contact with pool chemicals or lawn chemicals, direct contact with corrosive materials.

This warranty does not imply or assume any responsibility for consequential damages that might result from misuse, or improper installation of this cooking appliance. This warranty does not cover claims that do not involve defective workmanship or materials.

A bill of sale, cancelled check, or payment record must be kept to verify purchase date and establish warranty period. **Note: Empire Comfort Systems is committed to continuous product improvement. Materials and specifications are subject to change without notice.**







**THE MOST DURABLE GRILL  
KNOWN TO MAN**

**BROILMASTER®**  
is registered trademark of  
Empire Comfort Systems, Inc.  
918 Freeburg Ave.  
Belleville, Illinois 62220

VISIT OUR WEB SITE AT [www.broilmaster.com](http://www.broilmaster.com)